

ECV-H / ECV-V

Packaged Type Heat Recovery Unit





Index

ECV-H / ECV-V

Packaged Type Heat Recovery Unit

- Unit Components	2
- Performance Data	5
- Technical Specifications (ECV-H/ECV-V Series)	11
- Unit Dimensions (ECV-H Series)	13
- Service Space (ECV-H Series)	13
- Unit Dimensions (ECV-V Series)	14
- Service Space (ECV-V Series)	14
- Control System	15

Accessories

- Duct Type Electric Heaters	19
- Duct Type Heating Coil	20
- Duct Type Cooling Coil	21
- Duct Type DX Coil	21
- Duct Type Coil	22

General Terms and Conditions of Sale

24



The technical specifications and the performance data declared with this logo have been developed by the tests performed in Eeko Energy Laboratory which is established with the development Project support of Tübitak by regarding relevant standards.

Control System Plug&Play

ENECON PLUS and CORRIGO control units are developed for controlling of heat recovery units' equipments, meeting the demands coming from the customers and is user-friendly designed. ENECON PLUS and CORRIGO are capable of commanding the equipments in standard unit and optional accessories. ENECON PLUS and CORRIGO Control units can be performed the basic functions without any control panel, with Standard Panel can be also used more functional. Besides, the control unit can control the all functions via ModBus and switch on/off via BMS as optional and CORRIGO control unit can control the all functions via Bacnet. Alternatives different from ENECON PLUS and CORRIGO controllers are listed in "Control System" part.

Exhaust and Supply Air Filters

To increase indoor air quality and to protect the equipments used in unit, F class filter (according to EN 779 standard) is used for supply air streams; M class filter is used for exhaust air streams. A choice of pre-filters (G2-G4) and final filters (F6-F9) are available optionally. Optional filters reduce the available static pressure of the unit.

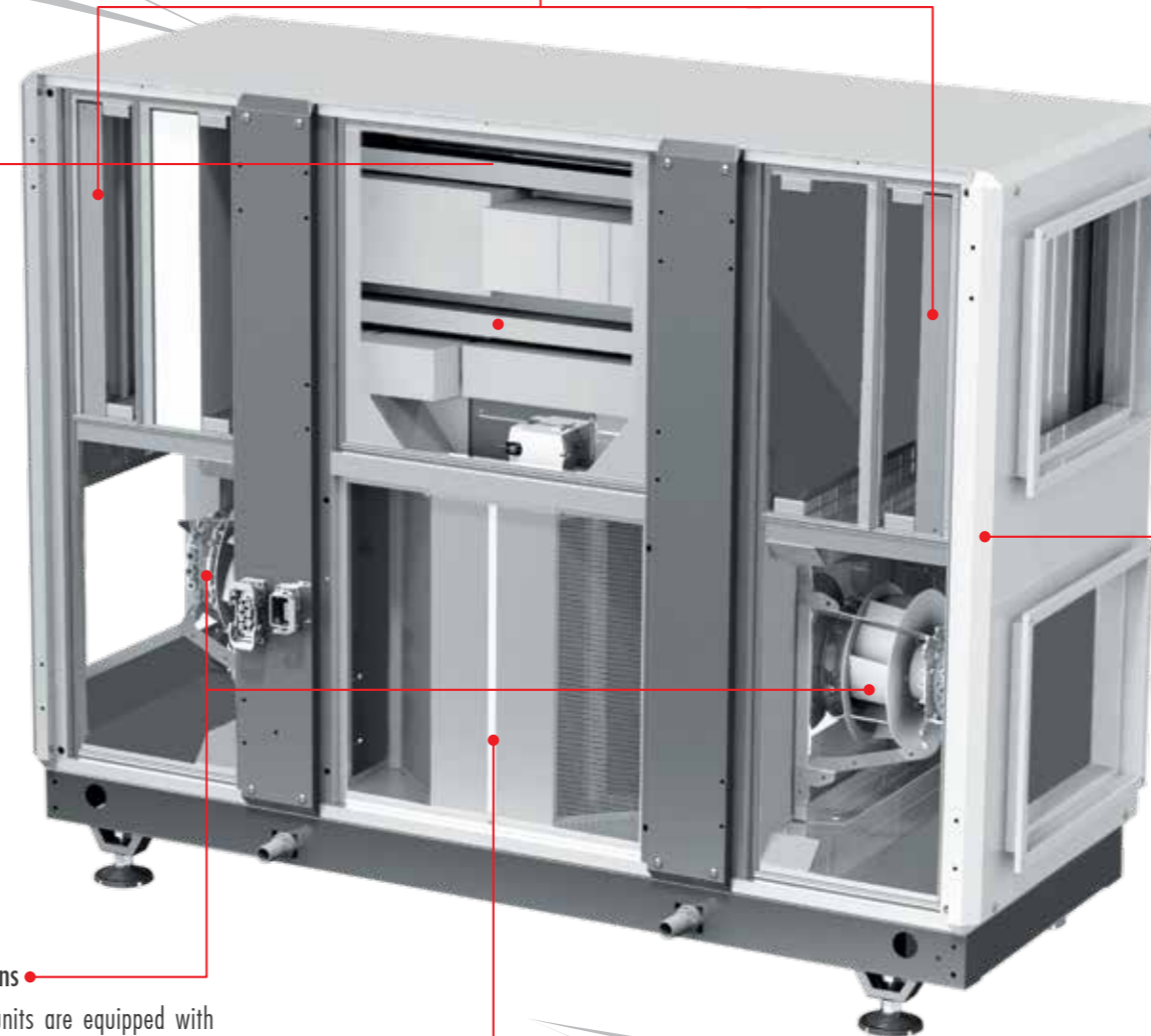

Casing & Insulation

The unit's casing is made up of double skinned high corrosion resistive 200 gr/m² galvanize coated steel. 50 mm thickness and 70kg/m³ density of Rockwool insulation between the walls is used for thermal and sound insulation. The case of unit is painted by electrostatic powdered paint. The unit is constructed in sections to ease transportation, mounting and commissioning.
Casing performance as per EN 1886
Casing air leakage: L1 (M)
Thermal bridges: TB2
Thermal transmission: T2
Mechanical strength: D1
Filter leakage: F9

Exhaust and Supply Air Fans

The fans in heat recovery units are equipped with innovative Electronically Commutated EC motor technology. EC motors have higher efficiency and simple speed control. Fan blades have high aerodynamic efficient backward curved design. EC motors reduce the energy consumption and increase the energy efficiency of the unit. With EC Fans, maintenance costs are reduced as the fans are directly connected to the motors; the belt and pulley problems are eliminated.

Heat Recovery Exchanger (Aluminum)

ECV-H heat recovery ventilation units have aluminum counterflow, high efficient plate heat recovery exchangers. Plate heat recovery exchangers have plates that are produced improved surface areas to provide high efficient and leakage free design. With the optimization of exchanger heat transfer is increased and pressure drop is decreased. Heat recovery exchanger has Eurovent certification.



Control System  Plug&Play

ENECON PLUS and CORRIGO control units are developed for controlling of heat recovery units' equipments, meeting the demands coming from the customers and is user-friendly designed. ENECON PLUS and CORRIGO are capable of commanding the equipments in standard unit and optional accessories. ENECON PLUS and CORRIGO Control units can be performed the basic functions without any control panel, with Standard Panel can be also used more functional. Besides, the control unit can control the all functions via ModBus and switch on/off via BMS as optional and CORRIGO control unit can control the all functions via Bacnet. Alternatives different from ENECON PLUS and CORRIGO controllers are listed in "Control System" part.



Exhaust and Supply Air Filters

To increase indoor air quality and to protect the equipments used in unit, F class filter (according to EN 779 standard) is used for supply air streams; M class filter is used for exhaust air streams. A choice of pre-filters (G2-G4) and final filters (F6-F9) are available optionally. Optional filters reduce the available static pressure of the unit.

Casing & Insulation

The unit's casing is made up of double skinned high corrosion resistive 200 gr/m² galvanize coated steel. 50 mm thickness and 70kg/m³ density of Rockwool insulation between the walls is used for thermal and sound insulation. The case of unit is painted by electrostatic powdered paint. The unit is constructed in sections to ease transportation, mounting and commissioning.

Casing performance as per EN 1886
Casing air leakage: L1 (M)
Thermal bridges: TB2
Thermal transmission: T2
Mechanical strength: D1
Filter leakage: F9

Exhaust and Supply Air Fans

The fans in heat recovery units are equipped with innovative Electronically Commutated EC motor technology. EC motors have higher efficiency and simple speed control. Fan blades have high aerodynamic efficient backward curved design. EC motors reduce the energy consumption and increase the energy efficiency of the unit. With EC Fans, maintenance costs are reduced as the fans are directly connected to the motors; the belt and pulley problems are eliminated.

Heat Recovery Exchanger (Aluminum)

ECV-V heat recovery ventilation units have aluminum counterflow, high efficient plate heat recovery exchangers. Plate heat recovery exchangers have plates that are produced improved surface areas to provide high efficient and leakage free design. With the optimization of exchanger heat transfer is increased and pressure drop is decreased. Heat recovery exchanger has Eurovent certification.



ECV-H 200

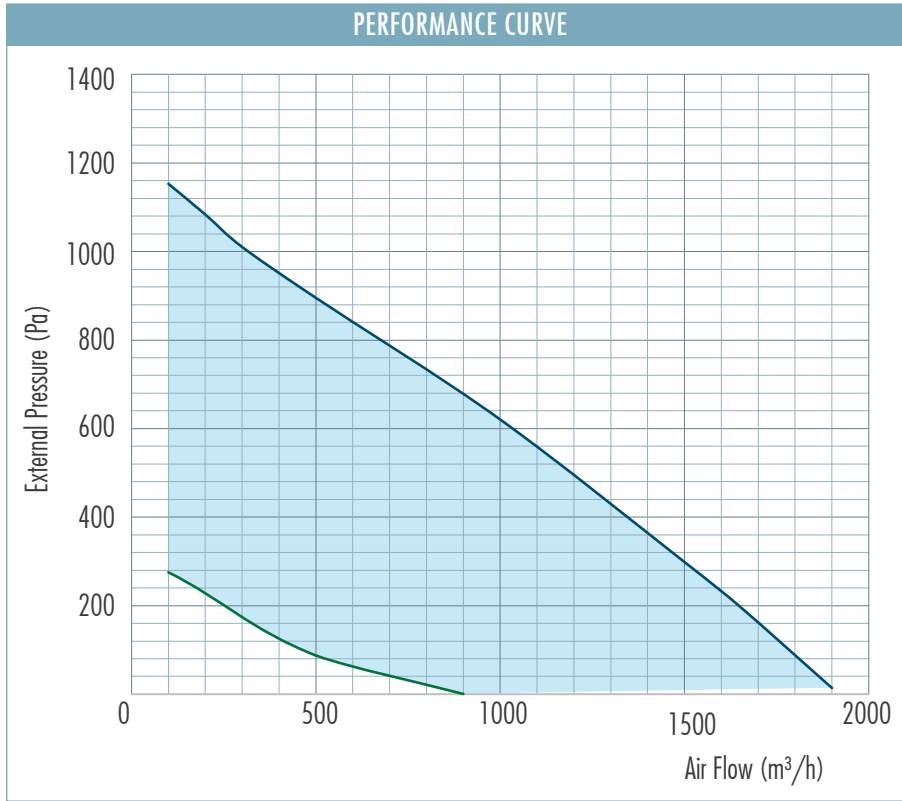

ECV-H 300

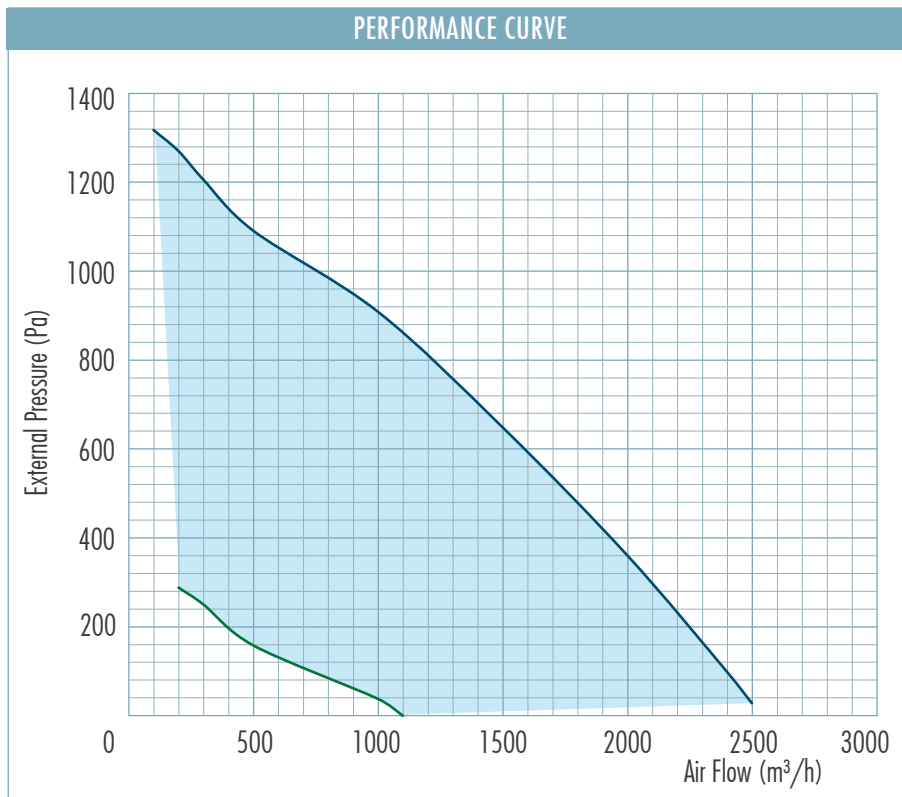

Note: Efficiency values are calculated according to EN 308 standard.



ECV-H 400

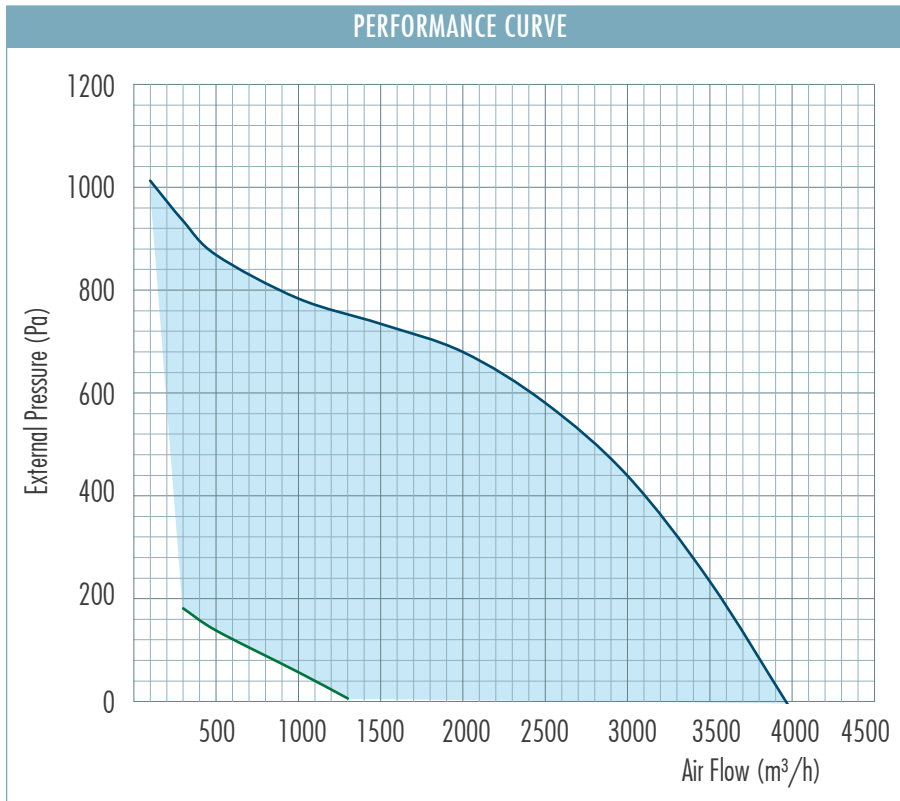

ECV-H 500

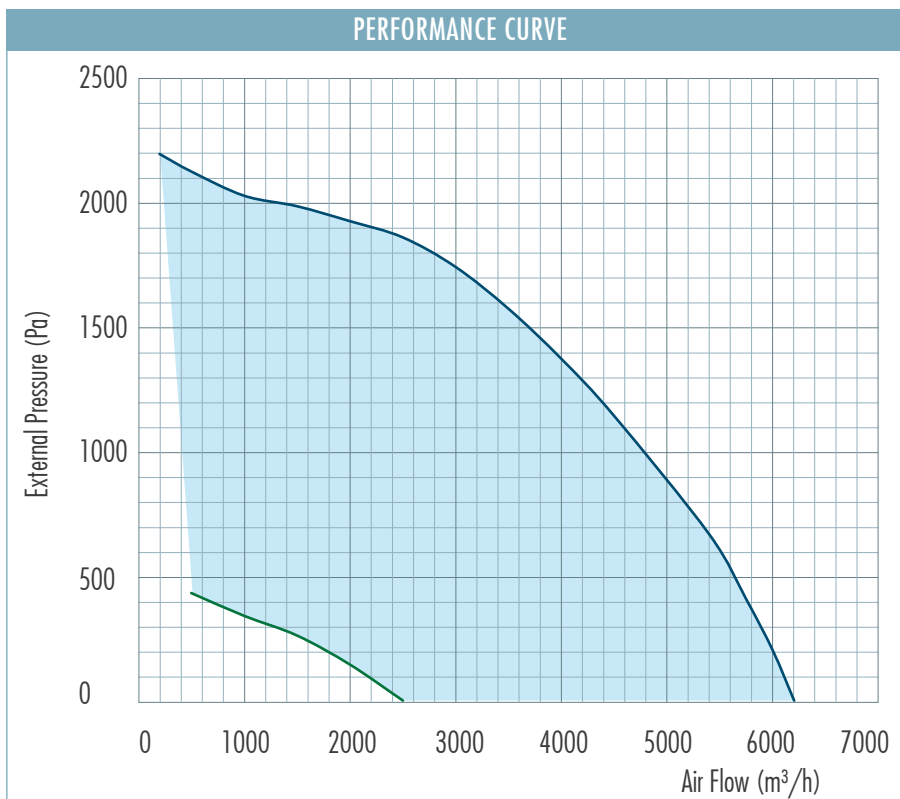

Note: Efficiency values are calculated according to EN 308 standard.



ECV-H 700

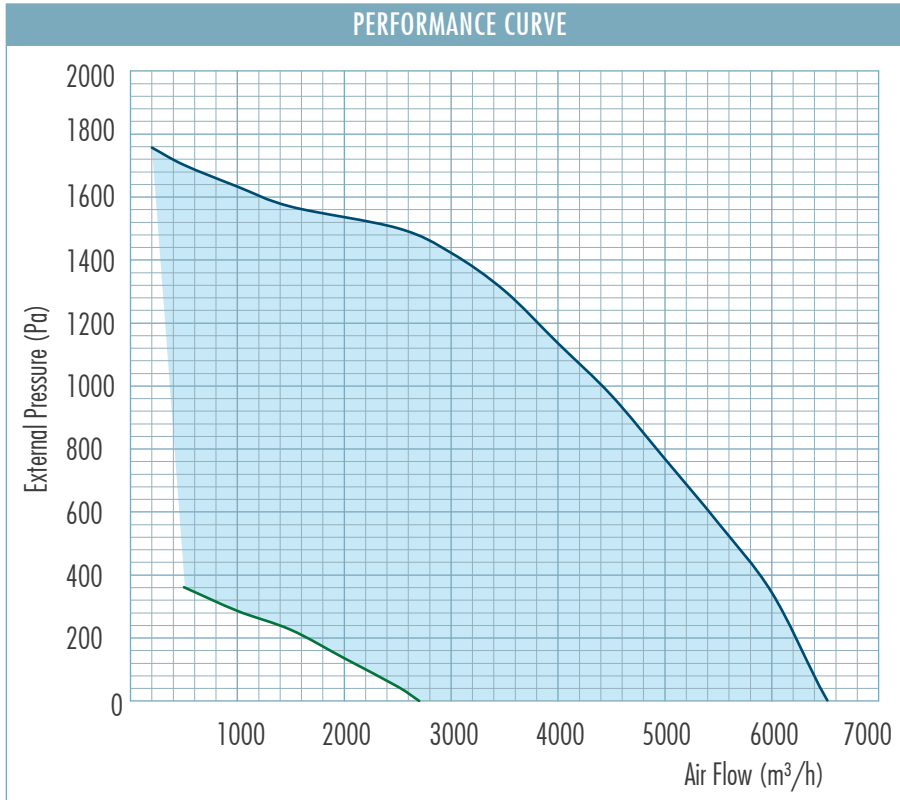

Note: Efficiency values are calculated according to EN 308 standard.



ECV-V 200

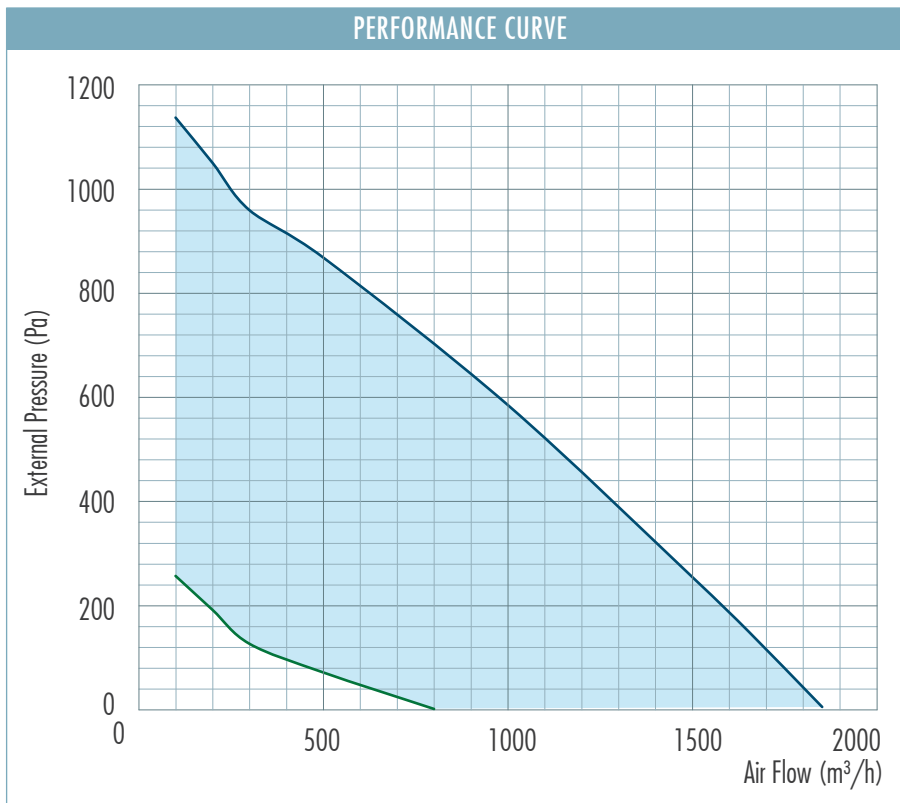

ECV-V 300

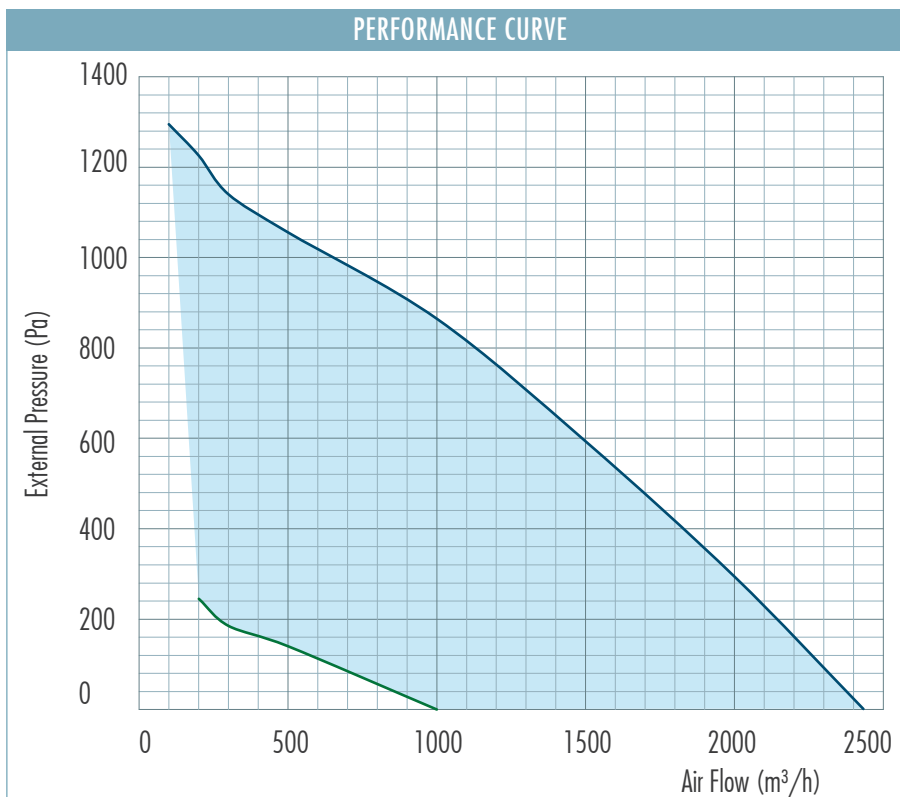

Note: Efficiency values are calculated according to EN 308 standard.



ECV-V 400

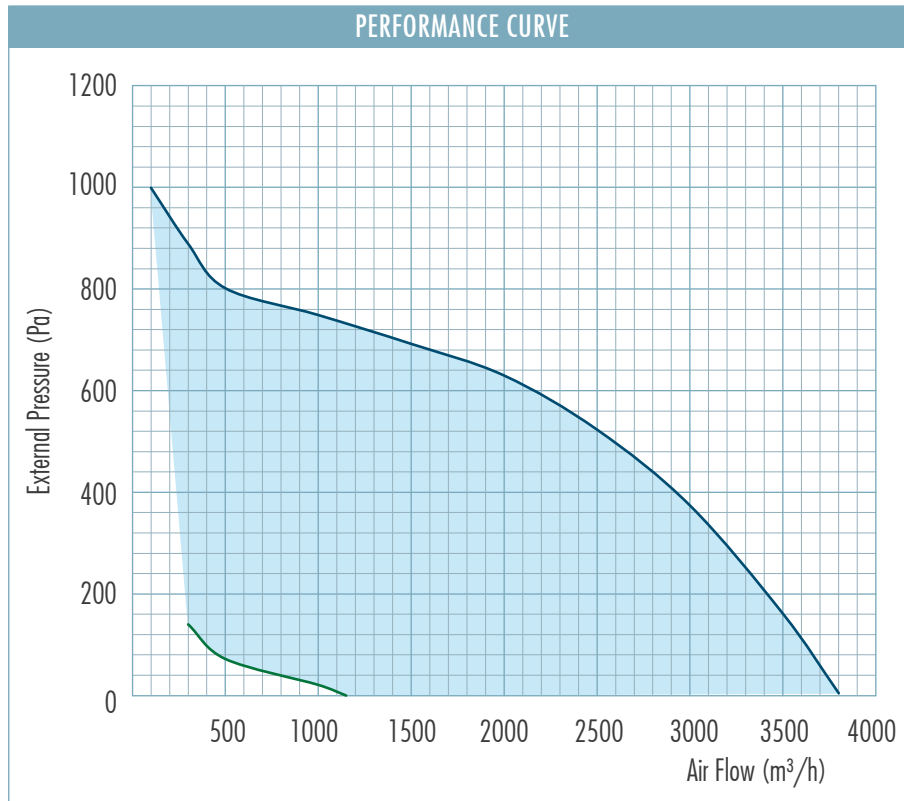

ECV-V 500

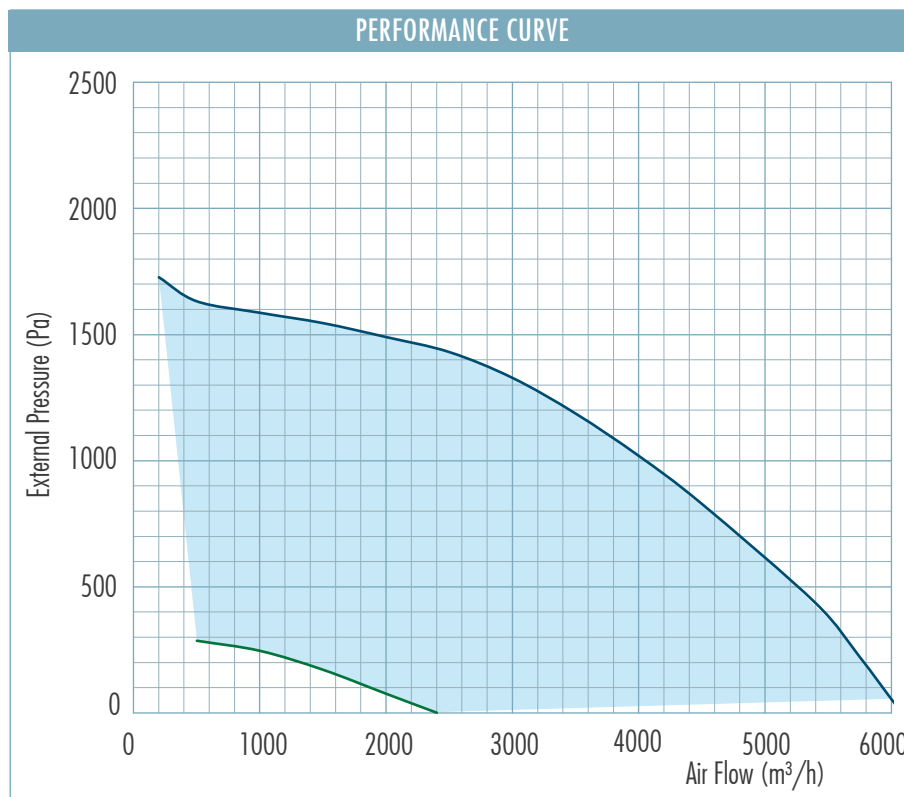

Note: Efficiency values are calculated according to EN 308 standard.



ECV-V 700

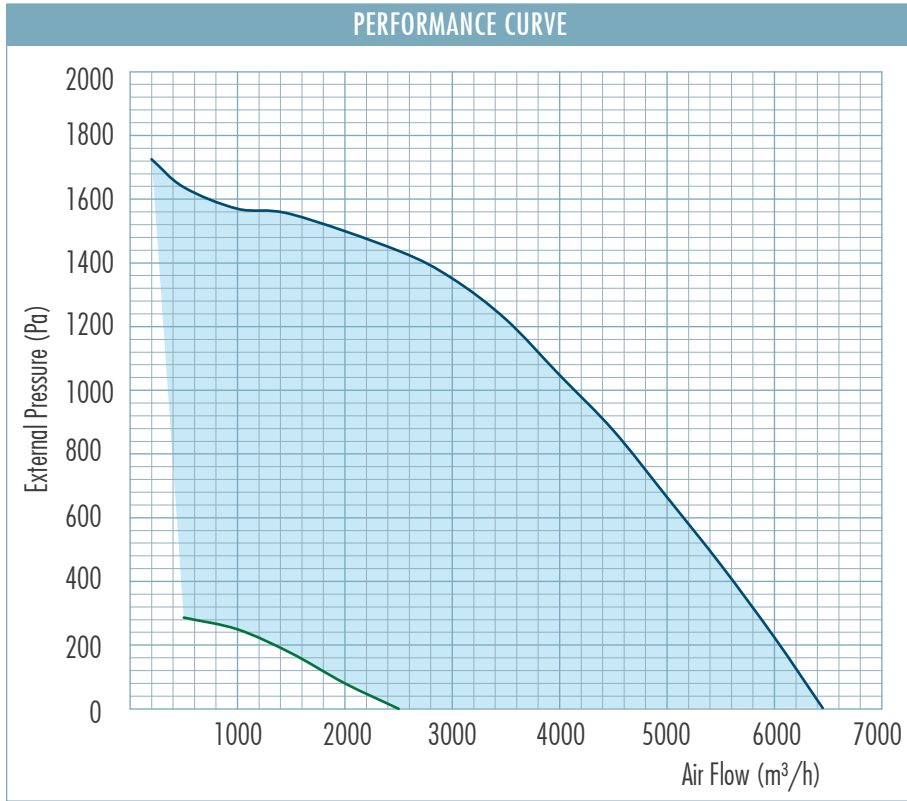

		ECV-H 200	ECV-H 300	ECV-H 400	ECV-H 500	ECV-H 700
Manufacturer		Eneko				
ERP		ERP 2018				
Declared typology		NRVU/BVU				
Type of drive installed or intended to be installed		Variable speed				
Type of HRS		Counterflow Plate Heat exchanger				
Thermal efficiency of heat recovery ¹	%	78,33	78,3	78,7	79,1	79,2
Nominal flow rate (Max ERP flow rate)	m ³ /h	1400	1950	3250	3350	3650
Maximum flow rate (200 Pa External Pressure Drop)	m ³ /h	1650	2250	3600	5800	6300
Effective electric power input	W	810	1100	1800	2000	4400
SFP _{int} ¹	W(m ³ /s)	1177	1170	1110	1136	1100
SFP _{int_limit} ¹	W(m ³ /s)	1201	1180	1136	1144	1134
Face velocity at nominal flow rate	m/s	1,26	1,5	1,65	1,7	1,73
Nominal external pressure drop ($\Delta P_{s,ext}$) ¹	Pa	200	200	200	200	200
Internal pressure drop of ventilation components ($\Delta P_{s,int}$) (ODA/EHA)	Pa	355/335	359/339	350/330	321/301	315/295
Internal pressure drop of non-ventilation components ($\Delta P_{s,add}$) (ODA/EHA)	Pa	There is no "non-ventilation" components				
Static efficiency of fans used in accordance with Regulation (EU) No. 327/2001 (Supply Fan/Exhaust Fan)	%	58.6/58.5	59.8/59.7	61.5/61.1	54.9/54.5	55.6/55.1
Maximum external leakage	%	<=3				
Maximum internal leakage	%	<=3				
Energy classification of filters (Energy performance) (Supply Air Side/Exhaust Air Side)	Kwh	482/403	696/588	1154/984	1342/1147	1455/1248
Description of visual filter warning for NRVUs intended for use with filters ²		Differential pressure measurement				
Sound power level (L _{WA})		52	52,1	56,2	52,4	53
Internet adress		www.eneko.com.tr				

¹ Measured at balanced flow, EN 308. Performance values will be change different working condition.

² Including test pointing out the importance of regular filter changes for performance and energy efficiency of the unit.

Note: ePM1 ≥ 50% (F7) class filter at supply side, ePM10 ≥ 50% (M5) class filter at exhaust side are used accordin to ISO 16890.

Technical Specifications

		ECV-V 200	ECV-V 300	ECV-V 400	ECV-V 500	ECV-V 700
Manufacturer		Eneko				
ERP		ERP 2018				
Declared typology		NRVU/BVU				
Type of drive installed or intended to be installed		Variable speed				
Type of HRS		Counterflow Plate Heat exchanger				
Thermal efficiency of heat recovery ¹	%	78,5	78,6	78,9	79,4	79,4
Nominal flow rate (Max ERP flow rate)	m ³ /h	1350	1850	3150	3200	3500
Maximum flow rate (200 Pa External Pressure Drop)	m ³ /h	1600	2200	3450	5600	6050
Effective electric power input	W	830	1400	1800	2050	4400
SFP _{int} ¹	W(m ³ /s)	1169	1160	1114	1156	1138
SFP _{int_limit} ¹	W(m ³ /s)	1208	1190	1144	1157	1147
Face velocity at nominal flow rate	m/s	1,68	2,3	2,5	2,6	2,8
Nominal external pressure drop ($\Delta P_{s,ext}$) ¹	Pa	200	200	200	200	200
Internal pressure drop of ventilation components($\Delta P_{s,int}$) (ODA/EHA)	Pa	351/331	358/338	360/340	328/308	330/310
Internal pressure drop of non-ventilation components($\Delta P_{s,add}$) (ODA/EHA)	Pa	There is no "non-ventilation" components				
Static efficiency of fans used in accordance with Regulation (EU) No. 327/2001 (Supply Fan/Exhaust Fan)	%	58.2/58.5	60/60.1	63/62.7	55.1/54.8	56.3/56
Maximum external leakage	%	<=3				
Maximum internal leakage	%	<=3				
Energy classification of filters (Energy performance) (Supply Air Side/Exhaust Air Side)	Kwh	510/430	755/652	1283/1122	1500/1314	1668/1468
Description of visual filter warning for NRVUs intended for use with filters ²		Differential pressure measurement				
Sound power level (LWA)		52,5	51,9	56,5	52,8	53,5
Internet adress		www.eneko.com.tr				

¹ Measured at balanced flow, EN308. Performance values will be change different working condition.

² Including test pointing out the importance of regular filter changes for performance and energy efficiency of the unit.

Note: ePM1 ≥ 50% (F7) class filter at supply side, ePM10 ≥ 50% (M5) class filter at exhaust side are used accordin to ISO 16890.

Unit Dimensions

ECV-H Unit Dimensions

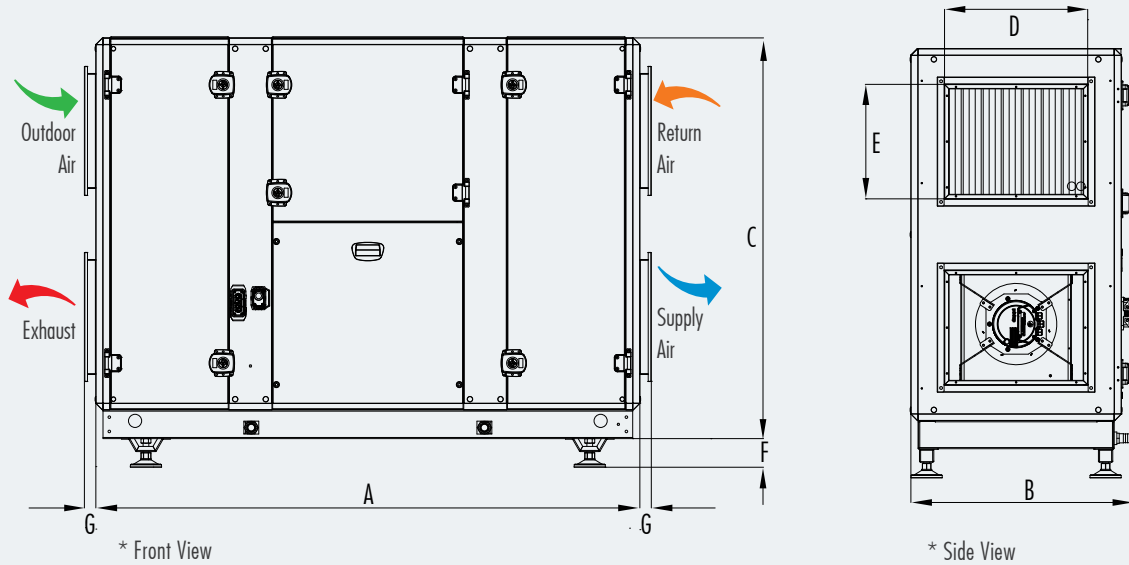

	ECV-H 200	ECV-H 300	ECV-H 400	ECV-H 500	ECV-H 700
A	1900	1900	2150	2150	2150
B	785	785	945	945	945
C	1240	1400	1645	1645	1745
DxE	500x400	500x400	600x500	600x500	600x600
F	100	100	100	100	100
G	40	40	40	40	40
Weight (kg)	275	305	420	425	485

*All measurement values are mm.

ECV-H Unit Service Space

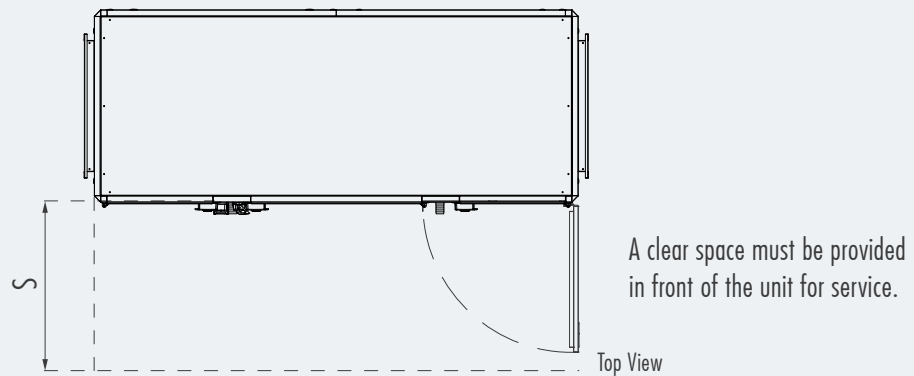

	ECV-H 200	ECV-H 300	ECV-H 400	ECV-H 500	ECV-H 700
S	800	800	900	900	900

"S" values indicate the size of the service area.

*All measurement values are mm.

ECV-V Unit Dimensions

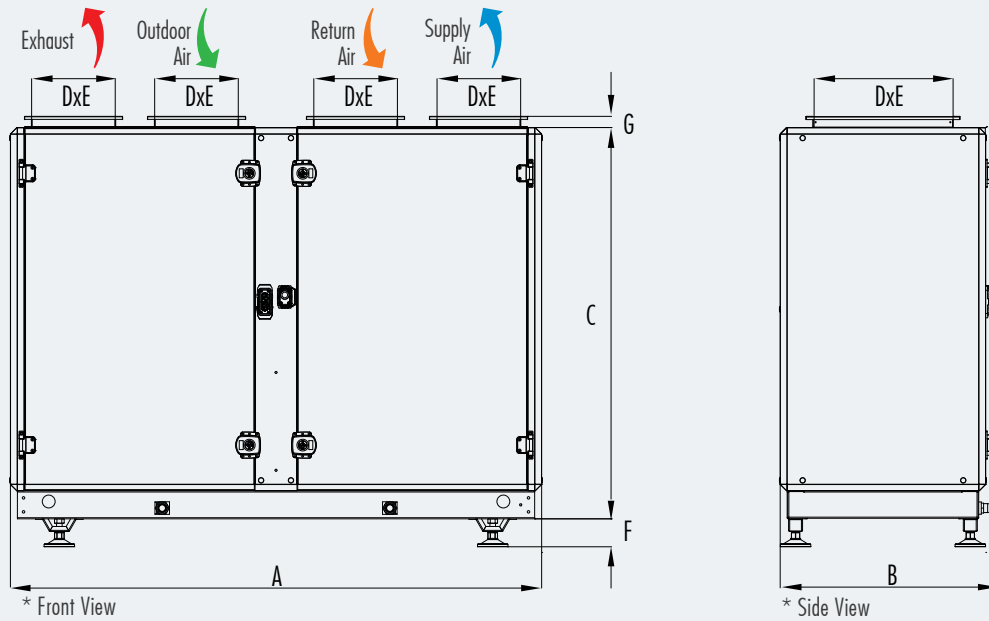

	ECV-V 200	ECV-V 300	ECV-V 400	ECV-V 500	ECV-V 700
A	1900	1900	2150	2150	2150
B	785	785	945	945	945
C	1240	1400	1645	1645	1745
DxE	500x300	500x300	700x400	700x400	700x400
F	100	100	100	100	100
G	40	40	40	40	40
Weight (kg)	275	305	420	425	485

*All measurement values are mm.

ECV-V Unit Service Space

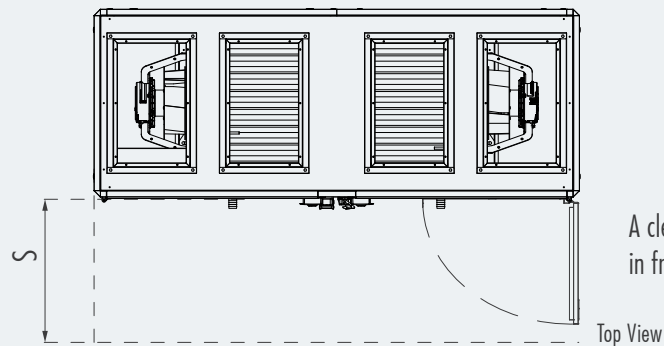

A clear space must be provided in front of the unit for service.

	ECV-V 200	ECV-V 300	ECV-V 400	ECV-V 500	ECV-V 700
S	900	900	1000	1000	1000

"S" values indicate the size of the service area.



*All measurement values are mm.

Control System

Automation Options		Control Cards	
Standard	Optional	Alternative 1	Alternative 2
		Enecon Plus	Corrigo
Outdoor Temperature		✓	✓
Extract Temperature		✓	✓
Supply Temperature		✓	✓
Supply Fan Control		✓	✓
Exhaust Fan Control		✓	✓
Fan Alarm		✓	✓
Dirty Filter Control (time)		✓	✓
Fire Alarm		✓	✓
External Low Speed		✗	✓
External Normal Speed		✗	✓
External High Speed		✗	✗
Dirty Filter Control (DPS)		✓	✓
Bypass On-Off Control		✓	✓
Bypass Proportional Control		✗	✓
General Alarm		✓	✗
	External High Speed	✓	✗
	Freeze Protection	✗	✓ (connected to exhaust)
	Exhaust Temperature	✗	✓
	Constant Flow	✗	☹
	Constant Pressure	✗	
	Humidity Control	☹	
	CO2 Control	☹	
	Heating Coil Water (On-Off)	✓	✓
	Cooling Coil Water (On-Off)	✓	✓
	DX Coil (On-Off)	✓	✓
	Heating Coil Water (Proportional)	✓	✓
	Cooling Coil Water (Proportional)	✓	✓
	Dx Coil (Proportional)	✓	✓
	Electrical Pre Heater	✓ (max3 Step)	✓ (1 Step)
	Electrical Post Heater (On-Off)	✓ (max3 Step)	✓
	Electrical Post Heater (Proportional)	✗	✗
	Damper (On-Off)	✓	✓
	Damper (Proportional)	✗	✗
	Exchanger Freezing Pressure Control	✗	✗
	Modbus RTU	✓	✓
	MODBUS IP	✗	✓
	BACnet MSTP	✗	✓
	BACnet IP	✗	✓
	Web Browser (TCP/IP)	✗	✓

☹ Only one of them the defined functions is selectable for this control card.

⚠ The optional features in the table vary according to the product.

Control Panel			Control Cards	
Panel Type	Panel Descriptions	Alternative 1	Alternative 2	
		Enecon Plus	Corrigo	
	Enecon Plus STD Panel	Wall-mounted type Max:30 m communication ability, Colour option: Black	☑	
	Enecon Plus Touch Button Panel	Wall-mounted type Max:30 m communication ability, Colour option: Black	☑	
	Enecon Plus Wifi Panel	Wall-mounted type Max:30 m communication ability, Colour option: White	☑	
	Enecon Plus 7 " Touch Panel	Wall-mounted type Max:30 m communication ability	☑	
	Corrigo STD Panel E3-DSP	Wall-mounted type hand panel, IP 30 protection class, Max:100 m communication ability		☑
	Corrigo STD Panel 4.3 " Panel	Wall-mounted type hand panel, IP 30 protection class, Max:100 m communication ability		☑
	Corrigo STD Panel 7 " Touch Panel	Wall-mounted type hand panel, IP 30 protection class, Max:100 m communication ability		☑

■ Selection of Electrical Cable Cross-Section

Unit Model ECV-H / ECV-V	Unit Voltage (V)	Unit Power Input (kW)	Current (A)	Fuse (A)	Cable Cross-Section(mm ²) for 50M and PF=0.8
200	230	1,14	4,8	2x6	2,5
300	230	1,64	6,8	2x10	2,5
400	400	2,34	3,6	3x4	2,5
500	400	5,94	8,98	3x10	2,5
700	400	5,94	8,98	3x10	2,5

The data in the table shows the maximum power/current values. Please check unit label for updated values.

■ Cable Cross-Section Formulas

$$1$$

$$I_{\text{current}} = \frac{P}{\sqrt{3} \cdot U \cdot \text{CosQ}}$$

$$I_{\text{cable}} > I_{\text{current}}$$

$$2$$

$$\%e = \frac{100 \cdot P \cdot L}{k \cdot S \cdot U^2}, \quad S = \frac{100 \cdot P \cdot L}{k \cdot \%e \cdot U^2}$$

$$\%e = \%3$$

$$3$$

$$I_{\text{cable}} > I_{\text{fuse}} \geq I_{\text{current}}$$

$$\text{Cable Cross-Section } S = \text{Max } (S1, S2, S3, 1.5\text{mm}^2)$$

* It is suitable for units with 400V supply voltage.

P : Power

I : Current

U : Voltage

S : Conductor cross section

k : Conductor coefficient

L : Conductor length

%e : The voltage drop

■ Example of Cable Cross-Section Calculation

$$P : 5,68\text{kW} \quad L : 50\text{m}$$

$$U : 400\text{V} \quad \%e : \%3$$

$$\text{CosQ} : 0,8 \quad k : 56\text{m} / \Omega$$

$$1$$

$$I_{\text{current}} = \frac{5680 \text{ W}}{\sqrt{3} \cdot 400 \cdot 0,8} = 10.25 \text{ A}$$

The cable will be used, is selected from the cable cross-section table so that the equivalent ampere value in the table should be higher than calculated "I_{current}" value.

$$S1 = 1.5 \text{ mm}^2$$

2

$$\%e = \%3$$

$$S = \frac{100 \cdot 5680 \cdot 50}{56 \cdot 3 \cdot 400^2}$$

$$S2 \geq 1 \text{ mm}^2$$

$$S2 = 1 \text{ mm}^2$$

3

$$I_{\text{cable}} > I_{\text{fuse}} \geq I_{\text{current}}$$

$$I_{\text{cable}} > 16\text{A} \geq 10.25\text{A}$$

"I_{fuse}", which will be higher than "I_{current}", is selected.

The cable will be used, is selected from the cable cross-section table so that the equivalent ampere value in the table should be higher than selected "I_{fuse}" value.

$$I_{\text{cable}} = 24\text{A}$$

$$S3 = 1.5 \text{ mm}^2$$

$$\text{Cable cross-section } S = \text{Max } (S1, S2, S3, 1.5\text{mm}^2)$$

$$S = \text{Max } (1.5, 1.5, 1.5, 1.5)$$

$$S = 1.5 \text{ mm}^2$$

■ Cable Cross-Section Formulas

1

$$I_{\text{current}} = \frac{P}{U \cdot \cos Q}$$

$$I_{\text{cable}} > I_{\text{current}}$$

2

$$\%e = \frac{100 \cdot P \cdot L}{k \cdot S \cdot U^2}, \quad S = \frac{100 \cdot P \cdot L}{k \cdot \%e \cdot U^2}$$

$$\%e = \%3$$

3

$$I_{\text{cable}} > I_{\text{fuse}} \geq I_{\text{current}}$$

$$\text{Cable Cross-Section } S = \text{Max} (S1, S2, S3, 1.5 \text{mm}^2)$$

* It is suitable for units with 230V supply voltage.

P : Power

I : Current

U : Voltage

S : Conductor cross section

k : Conductor coefficient

L : Conductor length

%e : The voltage drop

■ Example of Cable Cross-Section Calculation

P : 1,5kW

L : 50m

U : 230V

%e : %3

cosQ : 0,8

k : 56m / Ω

1

$$I_{\text{current}} = \frac{1500 \text{ W}}{230 \cdot 0,8} = 8.15 \text{ A}$$

The cable will be used, is selected from the cable cross-section table so that the equivalent ampere value in the table should be higher than calculated "I_{current}" value.

$$S1 = 1.5 \text{ mm}^2$$

2

$$\%e = \%3$$

$$S = \frac{100 \cdot 1500 \cdot 50}{56 \cdot 3 \cdot 230^2} = 0.84 \text{ mm}^2$$

$$S2 \geq 1 \text{ mm}^2$$

$$S2 = 1 \text{ mm}^2$$

3

$$I_{\text{cable}} > I_{\text{fuse}} \geq I_{\text{current}}$$

$$I_{\text{cable}} > 10A \geq 8.15A$$

"I_{fuse}" which will be higher than "I_{current}", is selected.

The cable will be used, is selected from the cable cross-section table so that the equivalent ampere value in the table should be higher than selected "I_{fuse}" value.

$$I_{\text{cable}} = 24A$$

$$S3 = 1.5 \text{ mm}^2$$

$$\text{Cable cross-section } S = \text{Max} (S1, S2, S3, 1.5 \text{ mm}^2)$$

$$S = \text{Max} (1.5, 1, 1.5, 1.5)$$

$$S = 1.5 \text{ mm}^2$$

■ Duct Type Electric Heaters



Electric heaters are optionally supplied in cold climates for supply air and in extreme climates for both supply and outdoor air sides against freezing. Electric heaters are manufactured according to rectangular duct systems. Standard types are produced of stainless steel heating elements and galvanized metal casing. Stainless steel casing is also available. Electric heaters are equipped with two circuit cutting thermostats. Factory setting for the automatically operating one is 70 °C and for the manual operating 110 °C. Electric heaters capacity can be controlled up to 2 or 3 steps with control system of unit according to the set temperature from the room control panel and room (or supply air) temperature. Speed controls shall not be used with Electric heater installations. Eneko electric heaters are connected in Delta connection in standard models.

Heating Capacity Calculation

$$Q = 0,33x V x (T_2 - T_1)$$

Q : Heating Capacity (W)

V : Air Flow through electric heater (m³/h)

T₁ : Air temperature before the heater (°C)

T₂ : Air temperature after the heater (°C)

Electrical Heater Capacity

Unit Model		Pre-heater		After-heater	
		Capacity (pre-heater) (kW) (Outdoor air between 0°C and -5°C)* Capacity 1	Capacity (pre-heater) (kW) (Outdoor air between -5°C and -15°C)* Capacity 2	Capacity (after-heater) (kW) (Heating the supply air to 25°C)* Capacity 1	Capacity (kW) (Heating the supply air to 25°C)** Capacity 2
ECV-H ECV-V	200	3	6	3	6
	300	7	12	7	12
	400	10	17	10	17
	500	14	25	14	25
	700	18	33	18	33

* All pre-heaters and after-heaters are duct type.

■ Duct Type Heating Coil / Cooling Coil



Duct type heating/cooling coils are assembled in modules as suitable to mount inside duct and have standard capacity. Coils consist of copper tubes and aluminum fins. Inlets and outlets of modules are suitable for duct connections as in heat recovery ventilation units. Additionally, cooling coils have drain pan and extra insulation to prevent condensation of modules.

Both heating and cooling coils can be controlled separately as on/off or proportionately via unit automation system. All values are calculated according to EN 308 standard.

■ Duct Type Heating Coil

Unit Model ECV-H / ECV-V	Air flow (m ³ /h)	90°C/70°C Water			80°C/60°C Water		
		Air side pressure drop (Pa)	Capacity (kW)	Fluid side pressure drop (kPa)	Air side pressure drop (Pa)	Capacity (kW)	Fluid side pressure drop (kPa)
200	1000	12,82	6,45	5,1	12,74	5,36	3,7
		24,69	11,9	30,3	24,42	10,03	22,2
300	1900	24,18	12,93	24,6	24,02	10,82	17,8
		43,95	22,58	33,1	43,48	19,07	24,3
400	2900	43,18	21,82	25,1	42,88	18,34	18,3
		73,55	35,17	25,7	72,72	29,64	18,9
500	4000	35,27	31,18	11,2	35,01	26,13	8,1
		60,17	49,94	12,3	59,46	41,94	8,9
700	5500	45,37	40,65	20	45,06	34,14	14,6
		77,23	65,65	22,3	76,37	55,24	16,3

Unit Model ECV-H / ECV-V	Air flow (m ³ /h)	70C/50C Water			60C/40C Water		
		Air side pressure drop (Pa)	Capacity (kW)	Fluid side pressure drop (kPa)	Air side pressure drop (Pa)	Capacity (kW)	Fluid side pressure drop (kPa)
200	1000	12,66	4,26	2,4	15,22	3,6	1,9
		24,15	8,15	15,3	23,88	6,26	10,3
300	1900	23,87	8,7	12	23,71	6,55	7,8
		43	15,54	16,8	42,52	11,96	11,1
400	2900	42,58	14,85	12,5	42,28	11,31	8
		71,89	24,06	13	71,05	18,42	8,5
500	4000	34,75	21,03	5,5	34,99	15,84	3,4
		58,74	33,87	6,1	58,02	25,66	3,8
700	5500	44,75	27,58	9,9	44,44	20,94	6,2
		75,5	44,77	11,1	74,63	34,15	7,1

Note: Calculated values are derived from different coils which can be fitted into same coilbox for each model in order to reach desired conditions.

■ Duct Type Cooling Coil

Unit Model ECV-H / ECV-V	Air flow (m ³ /h)	7°C/12°C Water				6°C/10°C Water			
		Air side pressure drop (Pa)	Capacity (kW)	Fluid side pressure drop (kPa)	Supply air temperature (°C)	Air side pressure drop (Pa)	Capacity (kW)	Fluid side pressure drop (kPa)	Supply air temperature (°C)
200	1100	28	4.4	4.1	14.6	33	5.8	6.4	12.9
	1710	59	6.4	8.4	15.7	67	7.9	11.2	14.5
300	1700	35	6.8	4.9	14.5	40	8.7	11.3	13.1
	2430	65	9.2	8.3	15.7	74	11.3	14.6	14.5
400	2200	25	9.6	7.3	13.8	28	12.6	13.3	12
	3740	61	14.9	12.1	15.3	69	18.6	27.3	14
500	3250	34	14	9.7	14.2	39	18	23.2	12.5
	5200	76	20.2	19	15.7	87	25.2	33.3	14.4
700	3900	25	15.1	4.8	14.4	28	19.7	5.9	12.8
	6900	66	24.7	5.9	16	75	30.5	13.2	14.9

■ Duct Type DX Coil

		R407C,5°C / 54°C			
Unit Model ECV-H / ECV-V	Air flow (m ³ /h)	Air side pressure drop (Pa)	Capacity (kW)	Fluid side pressure drop (kPa)	Supply air temperature (°C)
200	1100	36	6.5	4.7	13
	1710	76	8.5	7.9	15.2
300	1700	45	9.5	8.1	13.5
	2430	83	12	12.8	15.2
400	2200	31	13.7	13.1	12.2
	3740	77	19.6	23.6	14.7
500	3250	43	19.3	23.7	12.9
	5200	96	26.3	43.4	15.2
700	3900	32	22.8	25.8	12.8
	6900	86	32.9	52.5	15.6

		R410A,5°C / 54°C			
Unit Model ECV-H / ECV-V	Air flow (m ³ /h)	Air side pressure drop (Pa)	Capacity (kW)	Fluid side pressure drop (kPa)	Supply air temperature (°C)
200	1100	29	5.3	2.4	13.1
	1710	59	6.9	4.1	14.6
300	1700	35	7.9	4.8	13.6
	2430	65	9.9	7.4	14.8
400	2200	25	11.3	8.6	12.8
	3740	59	15.8	16.8	14.5
500	3250	33	15.7	16.2	13.3
	5200	75	20.9	28.7	14.9
700	3900	26	19.2	20.6	13.1
	6900	67	27.4	41.7	15

Note: Calculated values are derived from different coils which can be fitted into same coilbox for each model in order to reach desired conditions.

■ Duct Type Coil Dimensions

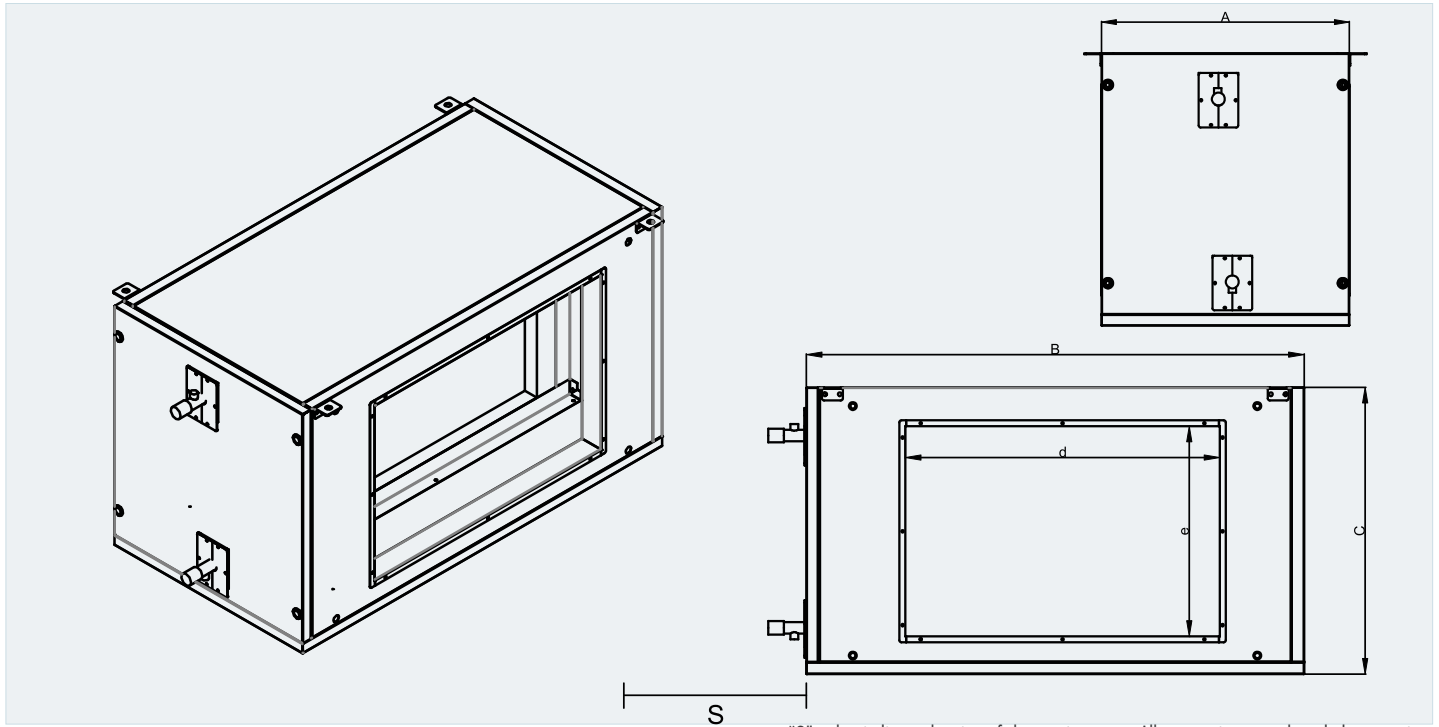

"S" value indicate the size of the service area. All connections are threaded connection.

Unit Model	Duct Type Water Coil Box Model	a	b	c	d	e	s	Weight (kg)
ECV-H/ECV-V 200	Heating Coil-Capacity 1	500	705	488,5	350	300	705	43,4
	Heating Coil-Capacity 2	500	705	488,5	350	300	705	44,1
	Change-Over Coil-Capacity 1	500	705	488,5	350	300	705	49,9
	Change-Over Coil-Capacity 2	500	705	488,5	350	300	705	54,3
	Dx Coil-Capacity 1	500	705	488,5	350	300	705	50
	Dx Coil-Capacity 2	500	705	488,5	350	300	705	53
	Electrical Heater-Capacity 1	500	705	488,5	350	300	705	45,6
	Electrical Heater-Capacity 2	500	705	488,5	350	300	705	46,8
ECV-H/ECV-V 300	Heating Coil-Capacity 1	500	805	552	450	300	805	51,1
	Heating Coil-Capacity 2	500	805	552	450	300	805	53,7
	Change-Over Coil-Capacity 1	500	805	552	450	300	805	59,9
	Change-Over Coil-Capacity 2	500	805	552	450	300	805	65,7
	Dx Coil-Capacity 1	500	805	552	450	300	805	60,6
	Dx Coil-Capacity 2	500	805	552	450	300	805	63,4
	Electrical Heater-Capacity 1	500	805	552	450	300	805	54,4
	Electrical Heater-Capacity 2	500	805	552	450	300	805	56,5
ECV-H/ECV-V 400	Heating Coil-Capacity 1	500	955	552	600	400	955	54,9
	Heating Coil-Capacity 2	500	955	552	600	400	955	57,9
	Change-Over Coil-Capacity 1	500	955	552	600	400	955	64,4
	Change-Over Coil-Capacity 2	500	955	552	600	400	955	71,2
	Dx Coil-Capacity 1	500	955	552	600	400	955	68,6
	Dx Coil-Capacity 2	500	955	552	600	400	955	67,6
	Electrical Heater-Capacity 1	500	955	552	600	400	955	58,7
	Electrical Heater-Capacity 2	500	955	552	600	400	955	61,3
ECV-H/ECV-V 500	Heating Coil-Capacity 1	500	1055	679	700	400	1055	70,3
	Heating Coil-Capacity 2	500	1055	679	700	400	1055	75,3
	Change-Over Coil-Capacity 1	500	1055	679	700	400	1055	83,6
	Change-Over Coil-Capacity 2	500	1055	679	700	400	1055	94,3

* All measurement values are mm.

■ Duct Type Dimensions

Unit Model	Duct Type Water Coil Box Model	a	b	c	d	e	s	Weight(kg)
ECV-H/ECV-V 500	Dx Coil-Capacity 1	500	1055	679	700	400	1055	86,6
	Dx Coil-Capacity 2	500	1055	679	700	400	1055	88,4
	Electrical Heater-Capacity 1	500	1055	679	700	400	1055	75,5
	Electrical Heater-Capacity 2	500	1055	679	700	400	1055	79,0
ECV-H/ECV-V 700	Heating Coil-Capacity 1	500	1185	679	800	400	1185	76,8
	Heating Coil-Capacity 2	500	1185	679	800	400	1185	82,3
	Change-Over Coil-Capacity 1	500	1185	679	800	400	1185	94,1
	Change-Over Coil-Capacity 2	500	1185	679	800	400	1185	104,4
	Dx Coil-Capacity 1	500	1185	679	800	400	1185	97,2
	Dx Coil-Capacity 2	500	1185	679	800	400	1185	104,3
	Electrical Heater-Capacity 1	500	1185	679	800	400	1185	82,8
	Electrical Heater-Capacity 2	500	1185	679	800	400	1185	86,7

* All measurement values are mm.



GENERAL

The sale of all Products of ENEKO shall exclusively be made on the basis of these General Terms and Conditions of Sales. Any other conditions and General Conditions of Purchase of the Buyer are not accepted.



OFFERS

Our offers are non-binding and without obligation. Contracts for delivery and all other agreements (including subsidiary agreements) as well as declarations of our representatives shall only become legally binding for us after written confirmation. We do not render planning service.

Proposals made and information provided by our representatives shall be non-binding. Illustrations, drawings, dimensions and weights or other performance data shall only be binding if this is expressly agreed in writing.



TERMS OF ORDER

Purchase orders shall be sent to ENEKO in written form and shall be non-binding unless they are accepted by written confirmation (order confirmation) from ENEKO. Each order shall include properly identified Products ordered and relevant shipping dates.



PRICE OF THE GOODS

Prices are net Ex Works according to current Incoterms unless stated otherwise and do not include any kind of taxes. Prices are valid at the date of delivery will be applied. We reserve the right to adjust prices for confirmed orders as well to reflect any increase in our costs for any reason beyond our control like force majeure, shortage of primary material or labor strikes, official orders, transportation or similar problems. In this case, a new price agreement shall be required for higher rates. If such an agreement is not made, we shall be entitled to withdraw from the contract by written notice within 15 days.



TERMS OF PAYMENT

Payments shall be carried out according to the contractual terms as defined and set forth in the order confirmation. If the payment conditions have not been agreed upon conclusion of the contract, the payment terms and payment dates specified in our invoices shall be binding. Deadlines for discounts and periods allowed for payment shall begin to run upon receipt of the invoice. Payments by draft, bills of Exchange or anyway extended payments shall mean neither credit novation, nor prejudice to the Retention of Title agreement, nor to territorial competence. If buyer fails to make payment by due date, we are entitled to charge the buyer with a relevant interest on the unpaid amount.



TERMS OF DELIVERY

Delivery time information is only approximate. We shall only be in default if the performance is due and a written demand for payment was issued. Delivery day is the day of dispatch Ex Works. We shall also not be liable with regard to bindingly agreed periods and dates in the event of delays on a delivery and of performance due to force majeure and events which considerably complicate or make delivery impossible not only temporarily-strike lockout, breakdown, delay in supply with important raw and auxiliary materials even if the delay occurs at our supplier, in particular. These delays entitle us to postpone delivery for the period of the impediment plus a reasonable start-up period or to withdraw from the contract as a whole or in part. If delivery time is extended or we are released from our delivery commitment, the buyer may not derive a claim for damages from it. However, we may only rely on the circumstances mentioned if we notify the buyer immediately. We shall be entitled to make part deliveries. Any part delivery shall be considered as independent transaction. In case of default, our liability is limited to contract-typical foreseeable damage.



SHIPMENT

Shipment is made for the buyer's account. Mode of shipment and shipping route, transport and packaging and other securities respectively shall be at our choice. We shall be entitled, however, not obliged to insure deliveries in the name and for account of the buyer. Risk passes to the buyer when shipment is handed over to the person performing the transport or left our Works for shipment. If shipment is delayed upon buyer's request, risk passes to the buyer with the ready for shipment note. If ordered goods are rejected after the ready for shipment note, we shall be entitled to request payment and store the goods at buyer's expense. Discharge of the goods is made at buyer's expense.



RETENTION OF TITLE

In any event ENeko shall retain full ownership of all materials supplied whilst the payment conditions of the entire amount have not been complied with, said materials may be removed from the customer at our request. Should the customer be declared bankrupt or insolvent and has not made paid the entire amount of payments. ENeko shall be entitled to recover the goods. ENeko may interrupt the supply without incurring any liability whatsoever if he had notice of or became aware of a decrease in the creditworthiness of the purchaser or if any of the existing negotiable instruments or debts were not properly complied with, shall result as being unpaid and protested.



WARRANTY

ENeko Products are under warranty (defect in material or workmanship) for 2 years from the date of sale reflected on the invoice. Under this warranty, ENeko is under the obligation to replace the part requested under warranty.

The followings are excluded from ENeko warranty:

- Normal wear and tear
- Defective assembly or handling
- Third party compensation

Parts the subject of a claim shall be sent to our warehouse as carriage paid with relevant report completely filled in, wherein the parts shall be subjected to analysis.



LIABILITY

ENeko, for any losses/damages, shall only be responsible within the limits of the law. Owing to basic obligations undertaken by simple negligence, if the contract is violated, ENeko's liability shall be limited to compensate for losses which are emerged specific and predictable. ENeko shall not carry any responsibility in case of a single negligence in breach of non-essential contractual obligations.



PROPERTY RIGHTS

The purchaser in no event and under no circumstances whatsoever shall publish or use the trademark, trade name or logo of ENeko without a prior written permission.



GOVERNING LAW AND JURISDICTION

This agreement shall be governed with all aspects of the Turkish Law. The courts of Izmir/Turkey shall have an exclusive jurisdiction to adjudicate any dispute arising under or in connection with this agreement.



ISTANBUL

Address : Cevizli District, Zuhal Avenue, Fusun Street, Ritim Istanbul A5 Block Floor: 25
No: 137, 34846 Maltepe/Istanbul Maltepe/Istanbul - TURKIYE

Tel. : +90 216 455 29 60 / +90 216 455 29 61

Fax. : +90 216 455 29 62

E-mail : satis@eneko.com.tr

IZMIR

Address : 10049 Street No: 04 AOSB 35620 Cigli/Izmir - TURKIYE

Tel. : +90 232 328 20 80

Fax. : +90 232 328 20 22

E-mail : export@eneko.com.tr

Web : www.eneko.com.tr

In parallel with our ongoing product development in R&D department, all rights of changing all technical specifications are reserved by ENEKO without any declaration and notice.

