

# EVHR / EVHR EC

Ceiling Type Heat Recovery Unit



## Index

### EVHR

#### Ceiling Type Heat Recovery Unit

- Unit Components	2
- Technical Specifications	5
- Performance Data	7
- Unit Dimensions	10
- Installation	11
Control System	12
Accessories	
- Electric Heaters	16
- Sound Attenuator For Circular Ducts	18
- Duct Type Circular External Damper	18
- Duct Type Heating/Cooling Coil	19
- Ventilaton on Demand	23
General Terms and Conditions of Sale	24



The technical specifications and the performance data declared with this logo have been developed by the tests performed in Eeko Energy Laboratory which is established with the development Project support of Tübitak by regarding relevant standards.

#### Casing & Insulation

High corrosion resistive 200 gr/m Galvanize coated steel is used for the casing. The unit is insulated from inside with 10 mm polyether foam against sound and thermal conduction.

#### Aluminum Cross-flow Heat Exchanger

EVHR heat recovery ventilation units have aluminum crossflow, plate heat recovery exchangers. Plate heat recovery exchangers have plates that are produced improved surface areas to provide high efficient and leakage free design. With the optimization of exchanger heat transfer is increased and pressure drop is decreased. Heat recovery exchanger has Eurovent certification.

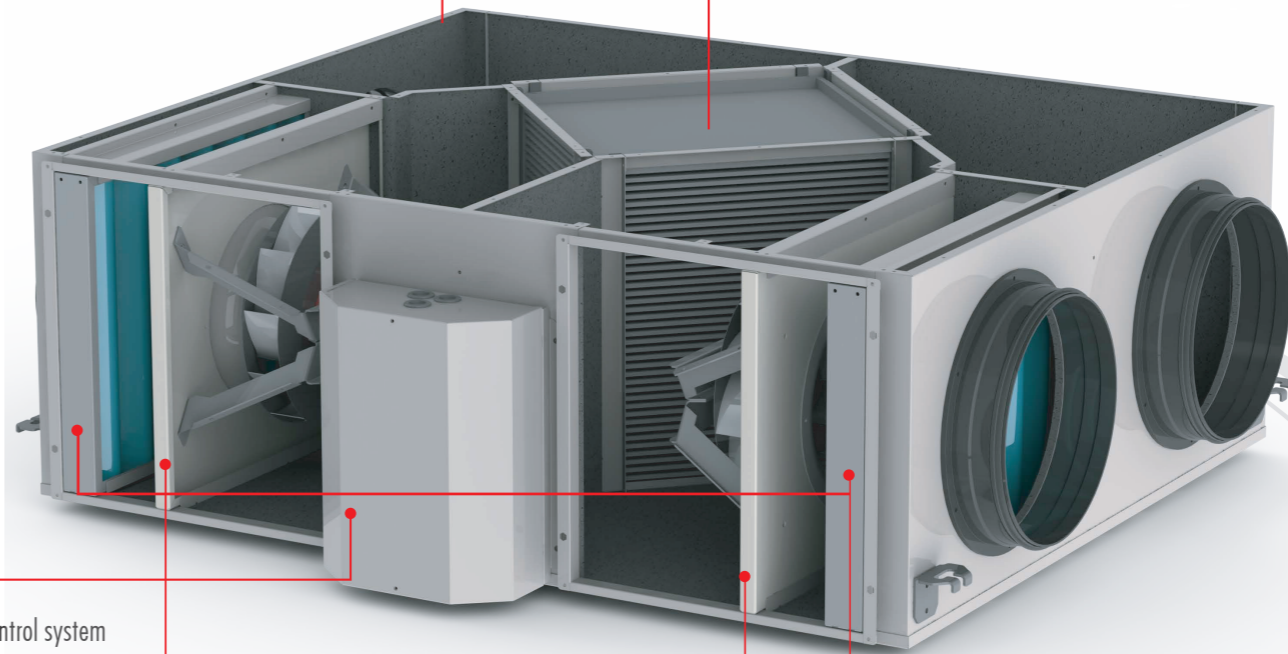

#### Control System

Units are equipped with a microprocessor based control system to meet various design needs. Both electrically and electronically control hardware comes with the unit that's why the unit is "Plug and Play". With the use of optional, CO2 sensor or constant flow kit, fans regulate automatically according to user demand. Room control panel is supplied where no BMS protocol is demanded. The panel is BMS compatible and can handle various communication protocols like Modbus and Bacnet. Control System is also capable of controlling heating/cooling capacity when units are used with heating/cooling coils.

#### Supply and Exhaust Air Filters

To increase indoor air quality and to protect the equipments used in unit, ISO Coarse 45% (G4) filters (according to EN 308 standard) are used for both exhaust and supply air streams. In duct-type ISO ePM1 >50% (F7) filters can be also used optionally. ISO ePM1 >50% (F7) filters reduce the available static pressure of the unit for the nominal air flow rate.

#### Supply and Exhaust Air Fans

Backward curved plug fans are used in EVHR units. Fan blades have high aerodynamic efficient backward curved design. Plug fans are used for high efficiency and low sound levels. With AC Fans, maintenance costs are reduced as the fans are directly connected to the motors; the belt and pulley problems are eliminated.

# EVHR 420 EC/820 EC/1020 EC/1520 EC/2020 EC/2520 EC/3020 EC/3520 EC/5020 EC/6020 EC Ceiling Type Heat Recovery Unit

## Casing & Insulation

High corrosion resistive 200 gr/m Galvanize coated steel is used for the casing. The unit is insulated from inside with 10 mm polyether foam against sound and thermal conduction.

## Aluminum Cross-flow Heat Exchanger

EVHR heat recovery ventilation units have aluminum crossflow, plate heat recovery exchangers. Plate heat recovery exchangers have plates that are produced improved surface areas to provide high efficient and leakage free design. With the optimization of exchanger heat transfer is increased and pressure drop is decreased. Heat recovery exchanger has Eurovent certification.

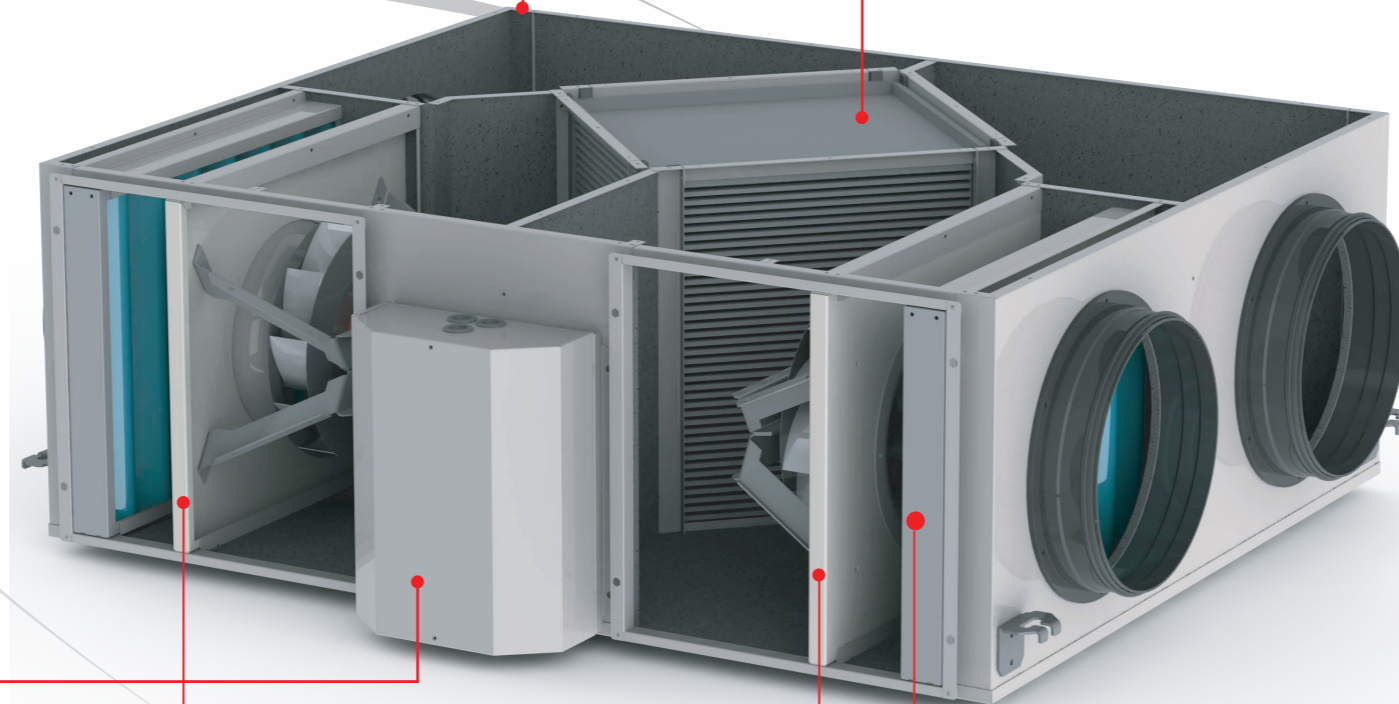

## Control System

Units are equipped with a microprocessor based control system to meet various design needs. Both electrically and electronically control hardware comes with the unit that's why the unit is "Plug and Play". With the use of optional, CO2 sensor or constant flow kit, fans regulate automatically according to user demand. Room control panel is supplied where no BMS protocol is demanded. The panel is BMS compatible and can handle various communication protocols like Modbus and Bacnet. Control System is also capable of controlling heating/cooling capacity when units are used with heating/cooling coils.

## Supply and Exhaust Air Filters

To increase indoor air quality and to protect the equipments used in unit, ISO Coarse 45% (G4) filters (according to EN 308 standard) are used for both exhaust and supply air streams. In duct-type ISO ePM1 >50% (F7) filters can also be used optionally. ISO ePM1 >50% (F7) filters reduce the available static pressure of the unit for the nominal air flow rate.

## Supply and Exhaust Air Fans

The fans in units are equipped with innovative Electronically Commutated EC motor technology. EC motors have higher efficiency and simple speed control. Fan blades have high aerodynamic efficient backward curved design. EC motors reduce the energy consumption and increase the energy efficiency of the unit. With EC Fans, maintenance costs are reduced as the fans are directly connected to the motors; the belt and pulley problems are eliminated.

Unit Type		EVHR 820	EVHR 1020	EVHR 1520	EVHR 2020	EVHR 2520	EVHR 3020	EVHR 3520	EVHR 5020	
Heat recovery efficiency <sup>1</sup>	(%)	Up to 57%								
Nominal air flow range	(m <sup>3</sup> /h)	655	840	1270	1560	2200	2560	3175	4000	
Maximum air flow range	(m <sup>3</sup> /h) (at 150 Pa)	590	780	1200	1320	2120	2400	2900	3800	
Max air flow range	(m <sup>3</sup> /h) (at 0 Pa)	810	950	1420	1600	2450	2780	3500	4600	
Nominal external pressure	(Pa)	100	100	100	100	100	100	100	100	
Unit Voltage	(V)	230	230	230	230	230	230	230	230	
Bypass		On/Off (Partial) optional								
Fan/Motor		AC Fan								
Fan Material		Composite / Metallic Impellers								
Heat Recovery Type		CrossFlow Heat Exchanger								
Installation		For indoor use only								
Installation Version		Horizontal								
Supply Air Filter		ISO Coarse 45% (G4)								
Exhaust Air Filter		ISO Coarse 45% (G4)								
Duct Connections		Circle								
Casing Material		Galvanized steel								
Direction Version		-								
Insulation Panel Type		10 mm insulation								
Service Access		The heat exchanger is serviced from the bottom, while all other accessories are serviced from the side.								
Accessories		See accessories page								

\*\*If unit selected with bypass module, max power consumption will be increase 100w.

\*\*Electrical heater and heater coil are optional. Electrical heaters shall be used before the fresh air inlet of the unit to preheat air where outdoor air is below -3°C and condensation can occur. Also in humid climates return air ducts must also be insulated against condensation.

<sup>2</sup>Nominal airflow, outdoor (5°C/72% RH) and indoor conditions (25°C/22%RH).

## ■ Sound Performance Data

Sound Pressure Levels (1,5 m) (dBA)

Unit Type	30% (dBA)	50 % (dBA)	70% (dBA)
820-AC	31,66	33,77	37,78
1020-AC	34,42	34,19	37,75
1520-AC	38,24	40,84	46,13
2020-AC	37,22	42,20	46,96
2520-AC	35,80	40,77	46,51
3020-AC	37,15	42,04	49,17
3520-AC	33,67	35,15	41,88
5020-AC	40,63	39,90	44,37

Sound Pressure Levels (3 m) (dBA)

Unit Type	30% (dBA)	50 % (dBA)	70% (dBA)
820-AC	25,64	27,75	31,76
1020-AC	28,40	29,17	31,73
1520-AC	32,22	34,82	40,11
2020-AC	31,20	36,18	40,94
2520-AC	29,78	34,75	40,49
3020-AC	31,13	36,02	43,15
3520-AC	27,65	29,13	35,86
5020-AC	34,61	33,88	38,35

Unit Type		EVHR 420 EC	EVHR 820 EC	EVHR 1020 EC	EVHR 1520 EC	EVHR 2020 EC	EVHR 2520 EC	EVHR 3020 EC	EVHR 3520 EC	EVHR 5020 EC	EVHR 6020 EC
Heat recovery efficiency <sup>1</sup>	(%)	Up to 58%									
Nominal air flow range	(m <sup>3</sup> /h)	420	960	1075	1930	2600	3075	3300	3575	4700	6250
Maximum air flow range	(m <sup>3</sup> /h) (at 150 Pa)	370	860	990	1860	2400	2870	3070	3500	4475	6040
Max air flow range	(m <sup>3</sup> /h) (at 0 Pa)	100	100	100	100	100	100	100	100	100	200
Nominal external pressure	(Pa)	43,4	57,8	48,8	48,4	44,4	44,5	44,5	40,7	44,6	45,6
Unit Voltage	(V)	230	230	230	230	230	230	230	400	400	400
Bypass		On/Off (Partial) optional									
Fan/Motor		EC Fan									
Fan Material		Composite / Metallic Impellers									
Heat Recovery Type		CrossFlow Heat Exchanger									
Installation		For indoor use only									
Installation Version		Horizontal									
Supply Air Filter		ISO Coarse 45% (G4)									
Exhaust Air Filter		ISO Coarse 45% (G4)									
Duct Connections		Round									
Casing Material		Galvanized steel									
Direction Version		-									
Insulation Panel Type		10 mm insulation									
Service Access		The heat exchanger is serviced from the bottom, while all other accessories are serviced from the side.									
Accessories		See accessories page									

\*If unit selected with bypass module,max power consumption will be increase 100w.

\*\*Electrical heater and heater coil are optional. Electrical heaters shall be used before the fresh air inlet of the unit to preheat air where outdoor air is below -3°C and condensation can occur. Also in humid climates return air ducts must also be insulated against condensation.

<sup>1</sup> Nominal airflow, outdoor (5°C/72% RH) and indoor conditions (25°C/22%RH).

## ■ Sound Performance Data

Sound Pressure Levels (1,5 m) (dBA)

Unit Type	30% (dBA)	50 % (dBA)	70% (dBA)
420-EC	35,94	38,41	40,69
820-EC	33,40	33,88	37,19
1020-EC	30,36	34,72	42,18
1520-EC	32,82	38,56	46,85
2020-EC	35,27	40,62	46,24
2520-EC	35,29	38,99	45,43
3020-EC	34,07	38,55	45,84
3520-EC	30,84	37,81	44,37
5020-EC	32,08	43,65	55,23
6020-EC	41,71	53,13	61,11

Sound Pressure Levels (3 m) (dBA)

Unit Type	30% (dBA)	50 % (dBA)	70% (dBA)
420-EC	29,92	32,39	34,67
820-EC	27,38	27,86	31,17
1020-EC	24,34	28,70	36,16
1520-EC	26,80	32,53	40,83
2020-EC	29,25	34,60	40,22
2520-EC	29,27	32,97	39,41
3020-EC	28,05	32,53	39,82
3520-EC	24,82	31,79	38,35
5020-EC	26,05	37,63	49,21
6020-EC	35,69	47,11	55,09

## EVHR 420 EC

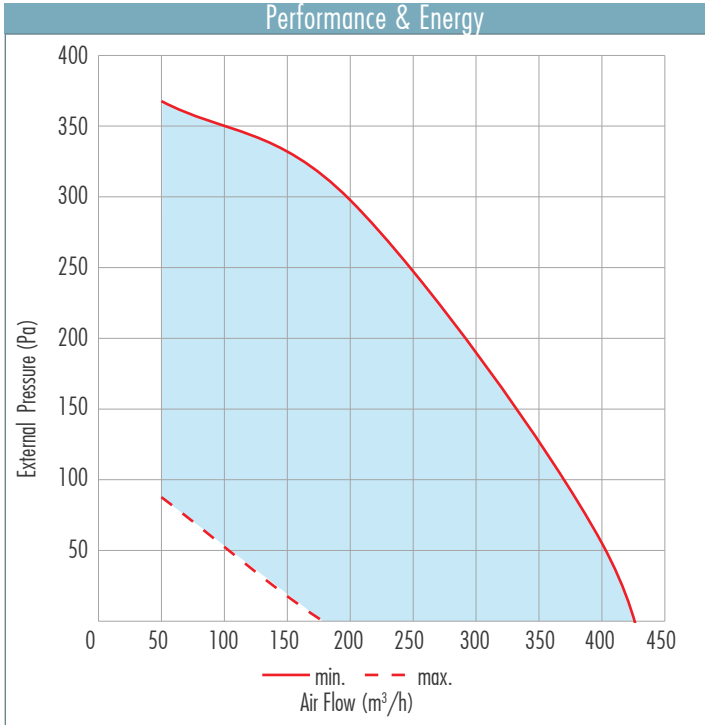

## EVHR 820

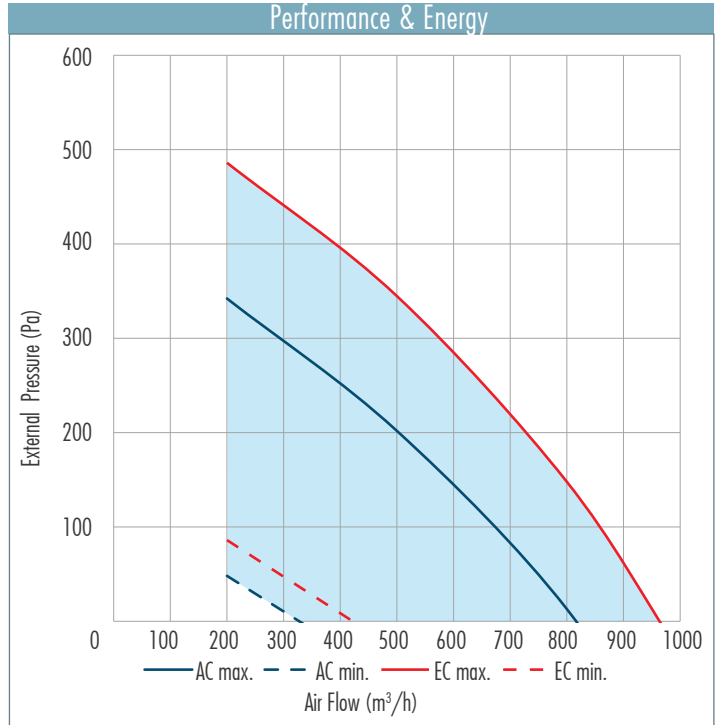

## EVHR 1020

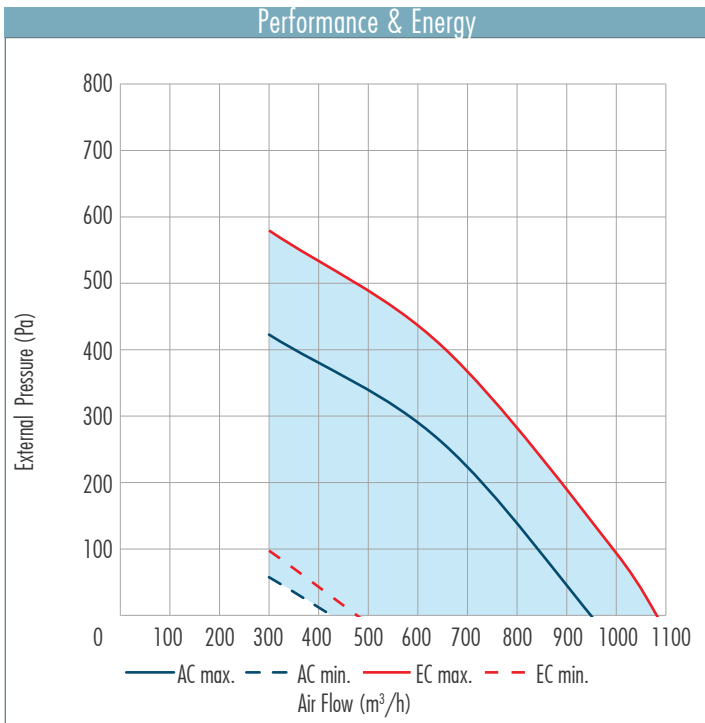

## EVHR 1520

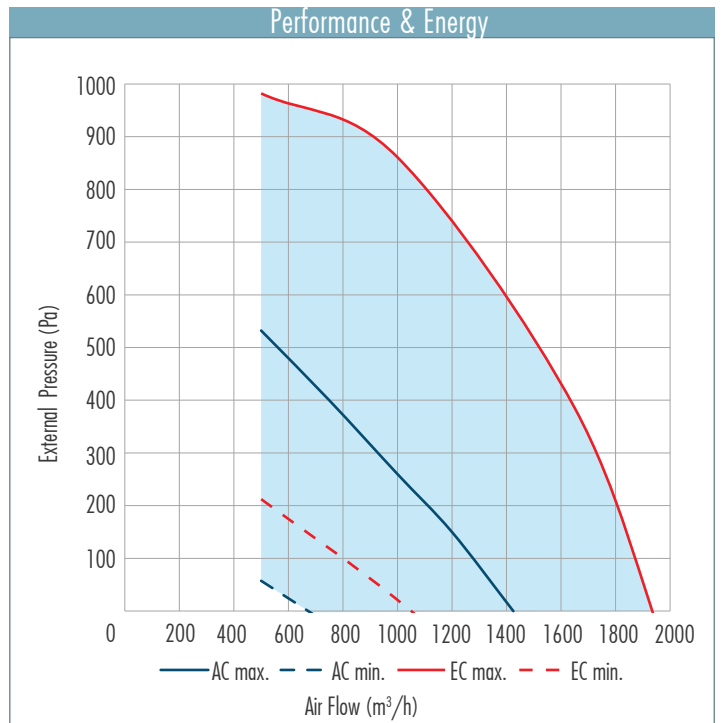

## EVHR 2020

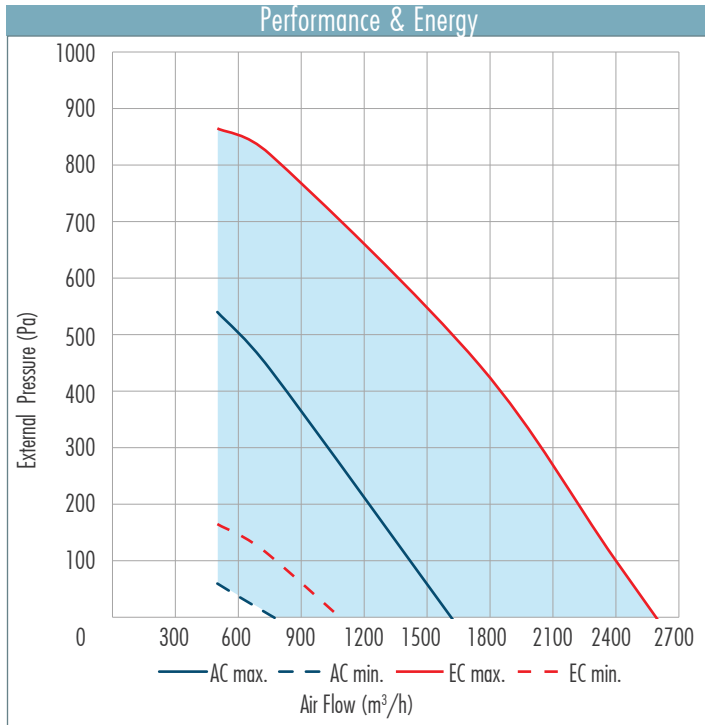

## EVHR 2520

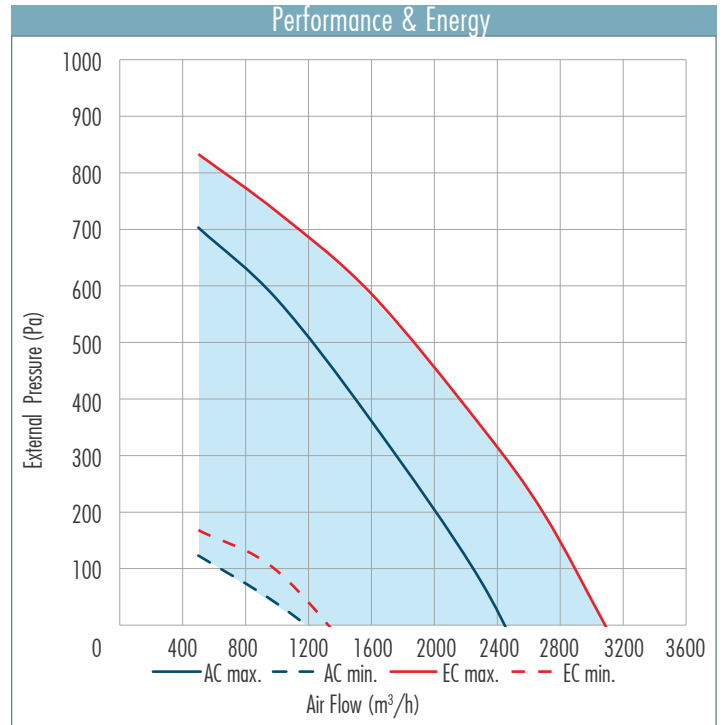

## EVHR 3020

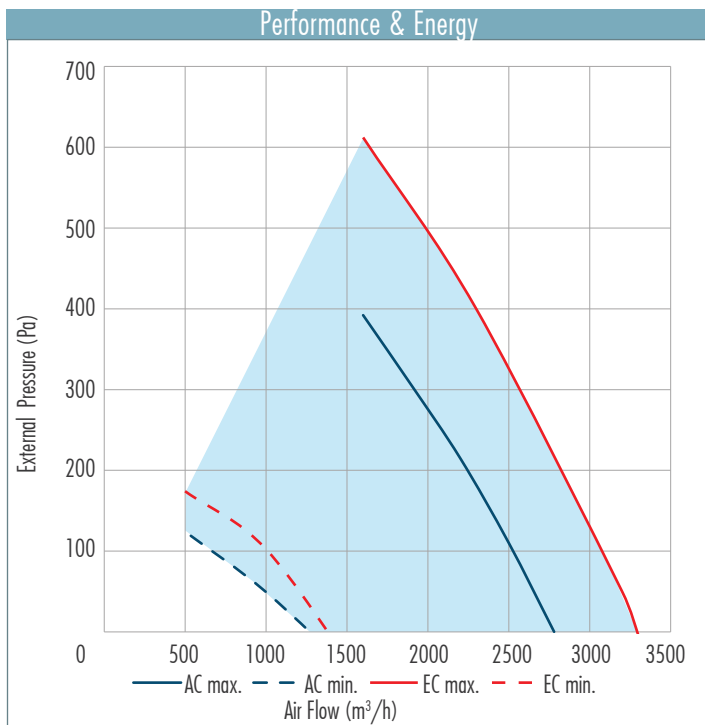

## EVHR 3520

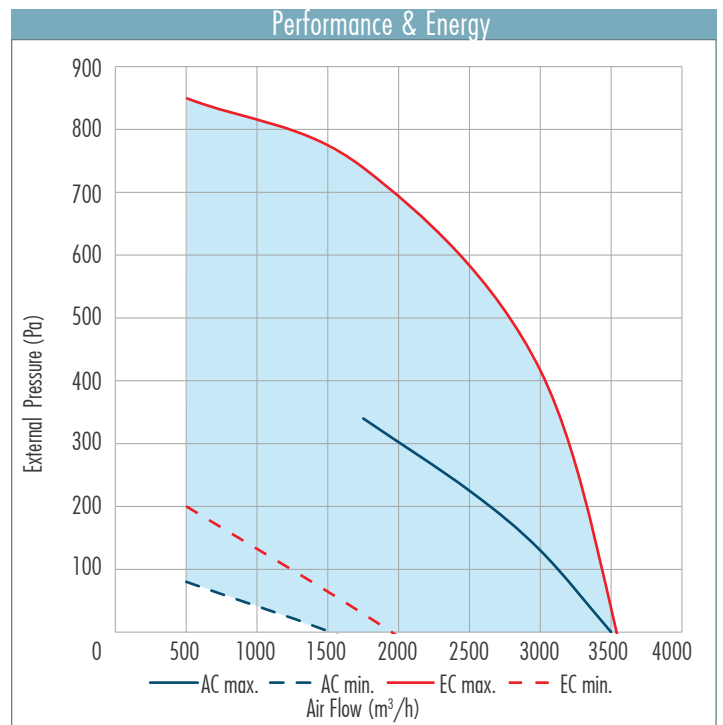

## EVHR 5020

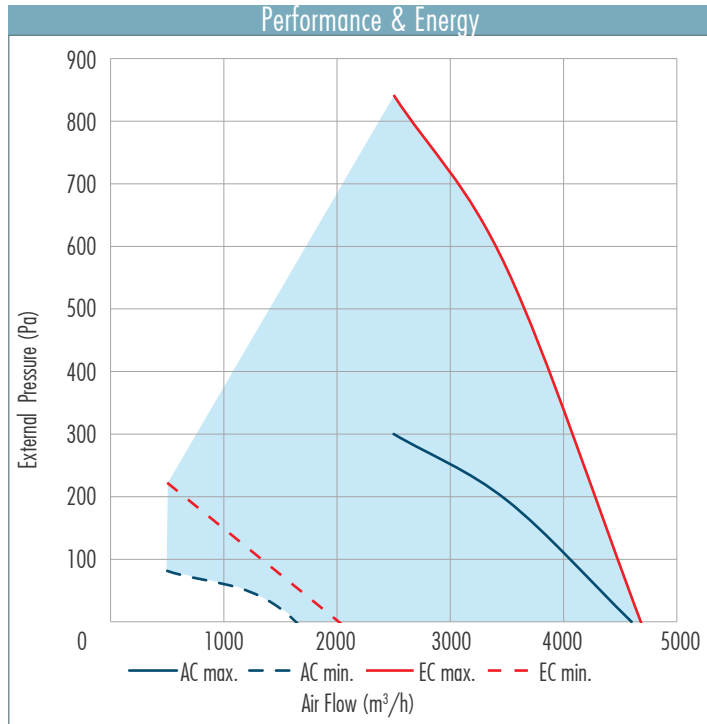

## EVHR 6020 EC

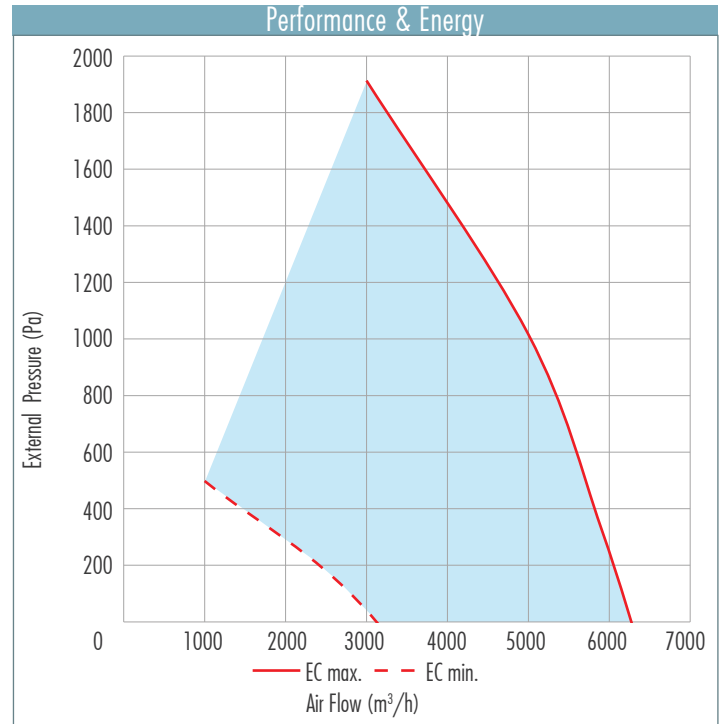

## EVHR Unit Dimensions

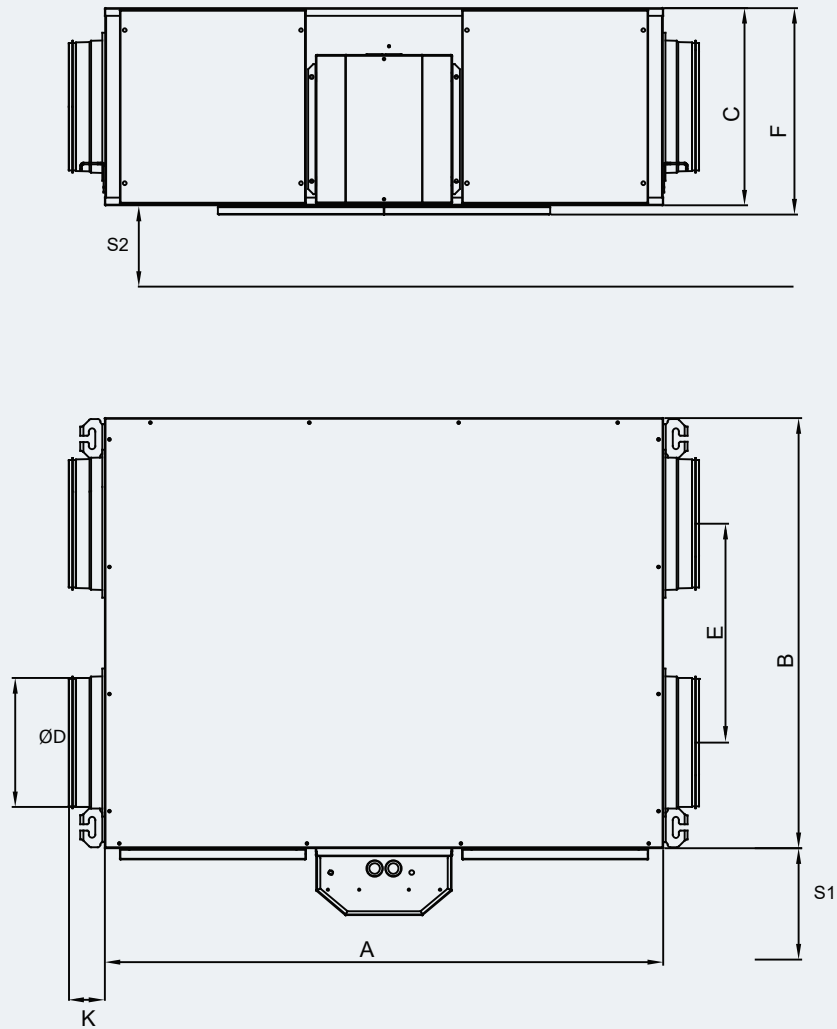

	EVHR 420 EC	EVHR 820 EVHR 820 EC	EVHR 1020 EVHR 1020 EC	EVHR 1520 EVHR 1520 EC	EVHR 2020 EVHR 2020 EC	EVHR 2520 EVHR 2520 EC	EVHR 3020 EVHR 3020 EC	EVHR 3520 EVHR 3520 EC	EVHR 5020 EVHR 5020 EC	EVHR 6020 EC
A	820	930	930	1072	1193	1335	1570	1570	1800	1800
B	500	680	680	826	980	1120	1160	1160	1170	1170
C	275	342	342	379	433	433	535	535	650	650
ØD	160	200	250	250	300	355	355	355	450	450
E	260	340	340	420	490	560	580	580	580	580
F	295	362	362	399	453	453	555	555	670	670
K	60	70	70	70	70	70	70	90	90	90
S1	500	500	500	500	600	700	700	700	750	750
S2	375	450	450	480	550	550	635	635	750	750

\* All measurement values are mm.

# Installation

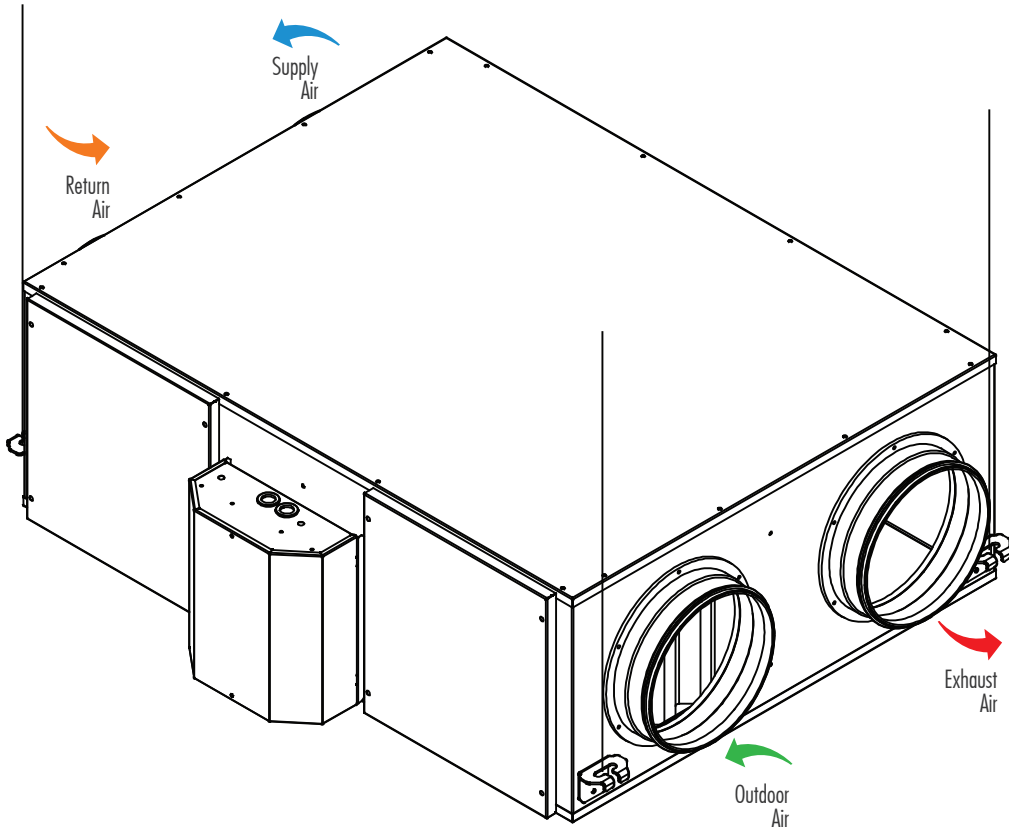

Automation Options		Control Cards
Standard	Optional	Enecon Plus (Standard)
Outdoor Temperature		☑
Extract Temperature		☑
Supply Fan Control		☑
Exhaust Fan Control		☑
Fan Alarm		☑
External Low Speed		☒
External Normal Speed		☒
External High Speed		☒
Fire Alarm		☑
Dirty Filter Control (Time)		☑
Modbus RTU		☑
MODBUS IP		☒
BacNET MSTP		☒
Weekly Timer		☑
	Bypass Damper	☑
	Damper(Proportional)	☒
	Constant Flow	☒
	Constant Pressure	☒
	Humidity Control	⊖
	CO2 Control	⊖
	BMS	⊖
	Supply Temperature	⊖
	Exhaust Temperature	☒
	Dx Coil Control(On/Off)	⊖
	Dx Coil Control(Proportional)	⊖
	Water Cooling Coil Control(Proportional)	⊖
	Water Heating Coil Control(On/Off)	⊖
	Electrical After-Heater (1 STEP)	⊖
	Water Heating Coil Control(Proportional)	☑
	Electrical Pre-Heater (1 STEP)	☑
	Electrical Pre-Heater (2 STEP)	⊖
	Damper (On-Off)	⊖
	Electrical After-Heater (2 STEP)	⊖
	Water Cooling Coil Control(On/Off)	⊖
	Freeze Protection	☑
	Exchanger Freezing Pressure Control	☒
	BacNET IP (with touchpanel)	☑
	Web Browser (TCP/IP)(with touchpanel)	☑
	Dirty Filter Control (DPS)	☑

⊖ Only one of defined functions is selectable for this control card.

⚠ The optional features in the table vary according to the product.

⚠ Technical staff should be consulted for IO information.

Enecon Plus		
	STD Panel	Wall-mounted type Max: 30 m communication ability
	Black Panel	Wall-mounted type Max: 30 m communication ability
	Touch Buton Panel	Wall-mounted type Max: 30 m communication ability
	Wired Black Panel with Wifi	Wall-mounted type Max: 30 m communication ability
	Wired Panel with Wifi	Wall-mounted type Max: 30 m communication ability
	Humidity Sensor	
	CO <sub>2</sub> Sensor	
	Differential Pressure Switch	

## ■ Stepless Control



- Stepless flow control
- Internal fuse
- On/Off function
- Flush mounted or surface mounted
- Compact design

Standard EVHR units are delivered to the site with fan speed regulators. With fan speed regulators, both exhaust and supply air fans are regulated and unit also can be switched on/off. Mains electricity is connected to the fan speed regulator where EVHR units shall be connected to the fan speed regulator there after.

## ■ Selection of Electrical Cable Cross-Section

Unit Model EVHR	Unit Voltage (V)	Unit Power Input (kW)	Current (A)	Fuse (A)	Cable Cross-Section(mm <sup>2</sup> ) for 50M and PF=0.8
820	230	0,24	1,08	2	1,5
1020	230	0,35	1,54	2	1,5
1520	230	0,69	3,02	3,15	2,5
2020	230	0,69	3,02	3,15	2,5
2520	230	1,06	4,68	5	2,5
3020	230	1,06	4,68	5	2,5
3520	230	1,02	4,92	6,3	2,5
5020	230	1,46	6,58	10	4

The data in the table shows the maximum power/current values. Please check unit label for updated values.

Unit Model EVHR EC	Unit Voltage (V)	Unit Power Input (kW)	Current (A)	Fuse (A)	Cable Cross-Section(mm <sup>2</sup> ) for 50M and PF=0.8
420	230	0,14	0,98	2	1,5
820	230	0,28	2,18	3,15	1,5
1020	230	0,38	2,98	3,15	1,5
1520	230	1,04	4,58	6,3	2,5
2020	230	1,04	4,58	6,3	2,5
2520	230	1,04	4,58	5	2,5
3020	230	1,04	4,58	5	2,5
3520	230	1,64	7,18	10	2,5
5020	400	2,24	3,58	3x4	2,5
6020	400	6,14	9,18	3x16	2,5

The data in the table shows the maximum power/current values. Please check unit label for updated values.

## ■ Cable Cross-Section Formulas

**1**

$$I_{\text{current}} = \frac{P}{U \cdot \cos Q}$$

$$I_{\text{cable}} > I_{\text{current}}$$

**2**

$$\%e = \frac{100 \cdot P \cdot L}{k \cdot S \cdot U^2}, \quad S = \frac{100 \cdot P \cdot L}{k \cdot \%e \cdot U^2}$$

$$\%e = \%3$$

**3**

$$I_{\text{cable}} > I_{\text{fuse}} \geq I_{\text{current}}$$

$$\text{Cable Cross-Section } S = \text{Max} (S1, S2, S3, 1.5\text{mm}^2)$$

- P : Power
- I : Current
- U : Voltage
- S : Conductor cross section
- k : Conductor coefficient
- L : Conductor length
- %e : The voltage drop

## ■ Example of Cable Cross-Section Calculation

P : 2,6 kW      L : 50m  
 U : 230V      %e : %3  
 PF: CosQ : 0.8      k : 56m / Ω

**1**

$$I_{\text{current}} = \frac{2600 \text{ W}}{230 \cdot 0,8} = 14.2 \text{ A}$$

The cable will be used, is selected from the cable cross-section table so that the equivalent ampere value in the table should be higher than calculated "I<sub>current</sub>" value.

$$S1 = 1.5 \text{ mm}^2$$

**2**

$$\%e = \%3$$

$$S = \frac{100 \cdot 2600 \cdot 50}{56 \cdot 3 \cdot 230^2} = 1.46 \text{ mm}^2$$

$$S2 \geq 1.46 \text{ mm}^2 \geq 1.5 \text{ mm}^2$$

$$S2 = 1.5 \text{ mm}^2$$

**3**

$$I_{\text{cable}} > I_{\text{fuse}} \geq I_{\text{current}}$$

$$I_{\text{cable}} > 16\text{A} \geq 14.2\text{A}$$

"I<sub>fuse</sub>" which will be higher than "I<sub>current</sub>", is selected.

The cable will be used, is selected from the cable cross-section table so that the equivalent ampere value in the table should be higher than selected "I<sub>fuse</sub>" value.

$$I_{\text{cable}} = 24\text{A}$$

$$S3 = 1.5 \text{ mm}^2$$

$$\text{Cable cross-section } S = \text{Max} (S1, S2, S3, 1.5 \text{ mm}^2)$$

$$S = \text{Max} (1.5, 1.5, 1.5, 1.5)$$

$$S = 1.5 \text{ mm}^2$$

## ■ Electric Heaters



Duct type electrical heaters are optionally supplied in cold climates for supply air and in extreme climates for both supply and outdoor air sides against freezing. Electric heaters are manufactured according to circular or rectangular duct systems.

Standard types are produced of stainless steel heating elements and galvanized metal casing. Stainless steel casing is also available. Electric heaters are equipped with two circuit cutting thermostats. Factory setting for the automatically operating one is 70 °C and for the manual operating 110 °C.

Electric heaters capacity can be controlled up to 3 steps with control panel according to the set temperature from the room control panel and room (or supply air) temperature. Speed controls shall not be used with Electric heater installations. Eneko electric heaters are connected in Delta connection in standard models.

### Heating Capacity Calculation

$$Q = 0,33 \times V \times (T_2 - T_1)$$

Q : Heating Capacity (W)

V : Air Flow through electric heater (m<sup>3</sup>/h)

T<sub>1</sub> : Air temperature before the heater (°C)

T<sub>2</sub> : Air temperature after the heater (°C)

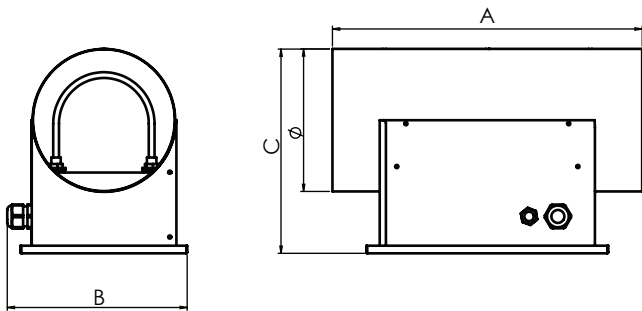

Unit Model		Capacity (kW)	A	B	C	Ø
EVHR	420 EC	1	430	210	262	160
		1,5	430	210	262	160
		2	430	210	262	160
		3	430	210	262	160
	820 820EC	1	430	250	284	200
		1,5	430	250	284	200
		2	430	250	284	200
		3	430	250	284	200
		4	430	250	284	200
	1020 1020 EC	1,5	430	300	341	250
		3	430	300	341	250
		4,5	430	300	341	250
		5	430	300	341	250
		6	430	300	341	250
	1520 1520 EC	1,5	430	300	341	250
		3	430	300	341	250
		4,5	430	300	341	250
		5	430	300	341	250
		6	430	300	341	250
	2020 2020 EC	2	500	307	367	300
3		500	307	367	300	
4		500	307	367	300	
5		500	307	367	300	
6		500	307	367	300	
7		500	307	367	300	
8		500	307	367	300	
10		500	307	367	300	

\*All measurement values are mm.

Unit Model		Capacity (kW)	A	B	C	Ø
EVHR	2520 2520 EC	4	500	325	478	355
		6	500	325	478	355
		7	500	325	478	355
		8	500	325	478	355
		10	500	325	478	355
		12	500	325	478	355
		16	500	325	478	355
	3020 3020 EC	4	500	325	478	355
		6	500	325	478	355
		7	500	325	478	355
		8	500	325	478	355
		10	500	325	478	355
		12	500	325	478	355
		16	500	325	478	355
	3520 3520 EC	4	500	325	478	355
		6	500	325	478	355
		7	500	325	478	355
		8	500	325	478	355
		10	500	325	478	355
		12	500	325	478	355
		16	500	325	478	355
	5020 5020 EC	5	500	425	527	450
		10	500	425	527	450
		13	500	425	527	450
		15	500	425	527	450
		18	500	425	527	450
		20	500	425	527	450
		6020 EC	5	500	425	527
10	500		425	527	450	
13	500		425	527	450	
15	500		425	527	450	
18	500		425	527	450	
20	500		425	527	450	

\*All measurement values are mm.

## Electrical Heater Capacity

Unit Model		Pre-heater/After-heater							
		Capacity (kW) 1	Capacity (kW) 2	Capacity (kW) 3	Capacity (kW) 4	Capacity (kW) 5	Capacity (kW) 6	Capacity (kW) 7	Capacity (kW) 8
EVHR	420 EC	1	1,5	2	3	-	-	-	-
	820/820EC	1	1,5	2	3	4	-	-	-
	1020/1020 EC	1,5	3	4,5	5	6	-	-	-
	1520/1520 EC	1,5	3	4,5	5	6	-	-	-
	2020/2020 EC	2	3	4	5	6	7	8	10
	2520/2520 EC	4	6	7	8	10	12	16	10
	3020/3020 EC	4	6	7	8	10	15	16	-
	3520/3520 EC	4	6	7	8	10	12	16	-
	5020/5020 EC	5	10	13	15	18	-	-	-
	6020 EC	5	10	13	15	18	-	-	-

\*The heaters indicated in colour are 3~/400/50

## ■ Sound Attenuator For Circular Ducts



Sound attenuators are designed for standard duct dimensions. Various lengths are available according to attenuation demand. Sound attenuation capacities are given in the table. For better performance sound attenuators can be used in series. For the best result the sound attenuators shall be installed just after the unit.

### Notation

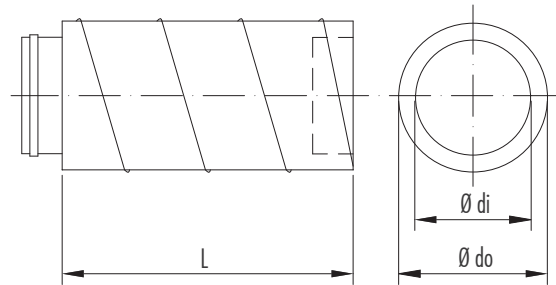
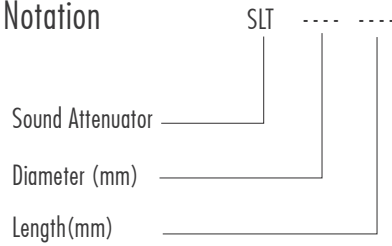

Sound Attenuator Capacity [dB]

UNIT MODEL	SLT	63	125	250	500	1k	2k	4k	8k	
EVHR	420 EC	160-600	1	4	8	19	37	28	17	11
	820/820EC	200-600	2	3	6	7	13	17	18	20
	1020/1020 EC	250-600	2	3	7	7	18	21	20	22
	1520/1520 EC	250-600	2	3	7	7	18	21	20	22
	2020/2020 EC	300-600	1	3	6	7	13	15	17	19
	2520/2520 EC	355-600	1	3	8	8	9	6	5	7
	3020/3020 EC	355-600	1	3	8	8	9	6	5	7
	3520/3520 EC	355-600	1	3	8	8	9	6	5	7
	5020/5020 EC	450-600	0.5	2	4	9	11	9	7	4
	6020 EC	450-600	0.5	2	4	9	11	9	7	4

Sound Attenuator Dimensions [mm]

UNIT MODEL	SLT	Length (L)	Ø di	Ø do	
EVHR	420 EC	160-600	600	160	220
	820/820EC	200-600	600	250	310
	1020/1020 EC	250-600	600	300	360
	1520/1520 EC	250-600	600	300	360
	2020/2020 EC	300-600	600	300	360
	2520/2520 EC	355-600	600	355	415
	3020/3020 EC	355-600	600	355	415
	3520/3520 EC	355-600	600	355	415
	5020/5020 EC	450-600	600	450	510
	6020 EC	450-600	600	450	510

\*All measurement values are mm.

## ■ Duct Type Circular External Damper

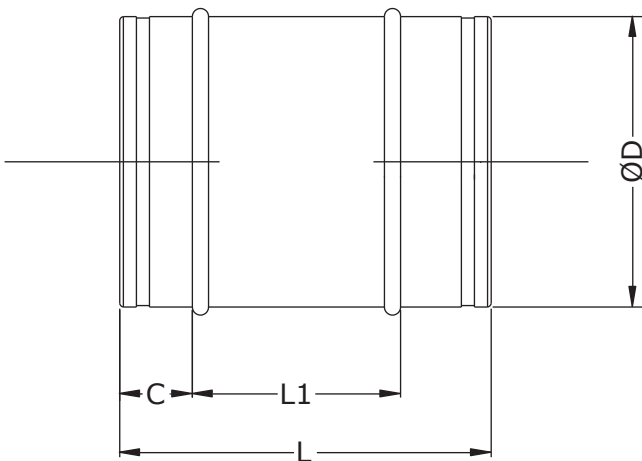

Unit Model	ØD	L	L1	C	
EVHR	420 EC	158	240	160	50
	820/820EC	198	280	180	50
	1020/1020EC	248	280	180	65
	1520/1520EC	248	280	180	65
	2020/2020EC	298	360	230	65
	2520/2520EC	353	400	270	65
	3020/3020EC	353	400	270	65
	3520/3520EC	353	400	270	65
	5020/5020EC	448	500	370	65
	6020/6020EC	448	500	370	65

\*All measurement values are mm.

Unit Model	Aeff(m2)	Qmin(m3/h)	Qmax(m3/h)	
EVHR	420 EC	0,031	170	1017
	820/820EC	0,031	170	1017
	1020/1020EC	0,049	265	1590
	1520/1520EC	0,049	265	1590
	2020/2020EC	0,071	382	2289
	2520/2520EC	0,099	534	3205
	3020/3020EC	0,099	534	3205
	3520/3520EC	0,099	534	3205
	5020/5020EC	0,159	858	5150
	6020/6020EC	0,159	858	5150

Aeff = Effective Area

Qmin = Air flow rate when the velocity in the duct is 1.5 m/s

Qmax = Air flow rate when the velocity in the duct is 9.0 m/s

### ■ Duct Type Heating Coil/Cooling Coil



Heating Coil



Cooling Coil

Duct type heating/cooling coils are assembled in modules as suitable to mount inside duct and have standard capacity. Coils consist of copper tubes and aluminum fins. Inlets and outlets of modules are suitable for duct connections as in heat recovery ventilation units. Additionally, cooling coils have drain pan and extra insulation to prevent condensation of modules. Both heating and cooling coils can be controlled separately as on/off or proportionately via automation system. All values are calculated according to EN 308 standard.

### ■ Duct Type Heating Coil

Unit Model	Air Flow (m <sup>3</sup> /h)	Duct Type Heating Coil Box Model	90°C/70°C Water			80°C/60°C Water		
			Air side pressure drop (Pa)	Capacity (kW)	Fluid side pressure drop (kPa)	Air side pressure drop (Pa)	Capacity (kW)	Fluid side pressure drop (kPa)
420 EC	370	Capacity 1	66,4	1,6	0,4	66,1	1,2	0,2
820/820EC	655	Capacity 1	33,5	3,9	3,9	33,3	3,3	2,8
1020/1020 EC	840	Capacity 1	53,2	4,5	5,0	52,3	2,1	1,2
1520/1520 EC	1270	Capacity 1	23,3	8,07	37,7	37,5	6,8	17,0
2020/2020 EC	1560	Capacity 1	55,3	9,0	28,8	55,0	7,6	21,0
2520/2520 EC	2200	Capacity 1	14,0	17,9	14,1	13,9	15,1	10,4
3020/3020 EC	2560	Capacity 1	18,1	19,6	16,7	17,9	16,5	12,2
3520/3520 EC	3175	Capacity 1	27,0	22,1	21,1	26,8	18,6	15,4
5020/5020 EC	4000	Capacity 1	41,4	25,1	19,8	41,2	21,2	19,6
6020 EC	6040	Capacity 1	89,3	31,3	29,9	88,8	26,3	21,9

■ Duct Type Heating Coil

Unit Model EVHR	Air Flow (m <sup>3</sup> /h)	Duct Type Heating Coil Box Model	70°C/50°C Water			60°C/40°C Water		
			Air side pressure drop (Pa)	Capacity (kW)	Fluid side pressure drop (kPa)	Air side pressure drop (Pa)	Capacity (kW)	Fluid side pressure drop (kPa)
420 EC	370	Capacity 1	65,6	0,8	0,1	65,4	0,6	0,1
820/820EC	655	Capacity 1	33,1	2,5	1,8	32,9	1,8	1,0
1020/1020 EC	840	Capacity 1	52,6	2,9	2,3	52,3	2,1	1,2
1520/1520 EC	1270	Capacity 1	37,3	5,5	11,6	37,1	4,2	7,1
2020/2020 EC	1560	Capacity 1	54,7	6,1	14,3	54,5	4,7	8,7
2520/2520 EC	2200	Capacity 1	13,8	12,2	7,1	13,7	9,4	4,4
3020/3020 EC	2560	Capacity 1	17,8	13,4	8,4	17,7	10,2	5,2
3520/3520 EC	3175	Capacity 1	26,6	15,1	10,5	26,5	11,5	6,5
5020/5020 EC	4000	Capacity 1	41,0	17,1	13,4	40,7	13,1	8,2
6020 EC	6040	Capacity 1	88,4	21,3	20,2	88,0	16,3	12,4

■ Duct Type Cooling (Changeover) Coil

Unit Model EVHR	Airflow (m <sup>3</sup> /h)	Duct Type Change-Over Coil Box Model	7°C/12°C Water			6°C/10°C Water		
			Air side pressure drop (Pa)	Capacity (kW)	Fluid side pressure drop (kPa)	Air side pressure drop (Pa)	Capacity (kW)	Fluid side pressure drop (kPa)
420 EC	370	Capacity 1	7,5	1,7	20,5	7,6	2,0	39,6
		Capacity 2	12,2	3,0	16,7	12,2	3,3	31,3
		Capacity 3	8,2	3,4	4,3	8,3	3,4	8,4
820/820EC	655	Capacity 1	29,1	4,2	31,5	29,2	4,7	59,3
		Capacity 2	17,4	2,4	36,4	-	-	-
		Capacity 3	7,7	6,4	7,7	7,7	7,2	16,5
1020/1020 EC	840	Capacity 1	25,4	5,7	11,5	25,6	6,6	22,6
		Capacity 2	11,7	9,5	11,7	11,6	10,6	16,1
		Capacity 3	19,4	4,7	8,1	19,5	5,4	15,7
1520/1520 EC	1270	Capacity 1	21,0	12,8	15,2	20,9	14,3	22,0
		Capacity 2	12,6	7,5	11,6	12,6	8,4	22,0
		Capacity 3	16,5	10,8	24,3	16,5	12,0	36,3
2020/2020 EC	1560	Capacity 1	17,8	8,4	14,4	17,8	9,4	21,8
		Capacity 2	22,1	12,3	24,8	22,1	13,7	46,1
		Capacity 3	17,3	18,5	11,6	17,2	20,4	21,1
2520/2520 EC	2200	Capacity 1	21,7	10,6	8,7	21,9	21,1	17,1
		Capacity 2	27,7	23,8	18,3	27,6	26,3	29,4
		Capacity 3	12,1	20,3	14,8	12,1	22,7	27,4
3020/3020 EC	2560	Capacity 1	29,1	11,6	10,2	29,3	13,2	19,9
		Capacity 2	22,1	29,2	16,8	22,0	32,2	30,4
		Capacity 3	14,9	22,5	17,5	14,9	25,0	32,1
3520/3520 EC	3175	Capacity 1	24,8	17,5	12,9	24,9	19,8	24,4
		Capacity 2	29,9	34,0	22,2	29,8	37,6	34,5
		Capacity 3	20,2	25,7	22,7	20,2	28,7	37,2
5020/5020 EC	4000	Capacity 1	37,7	19,9	16,3	37,9	22,4	30,8
		Capacity 2	41,9	39,8	29,7	41,7	44,1	46,1
		Capacity 3	28,3	29,5	29,4	28,4	33,0	48,0
6020 EC	6040	Capacity 1	44,1	26,2	23,6	44,3	29,4	38,6

### ■ Duct Type DX Coil

Unit Model EVHR	Air Flow (m <sup>3</sup> /h)	Duct Type DX Coil Box Model	R32,4°C/45°C			R410A,4°C/45°C		
			Air side pressure drop (Pa)	Capacity (kW)	Fluid side pressure drop (kPa)	Air side pressure drop (Pa)	Capacity (kW)	Fluid side pressure drop (kPa)
420 EC	370	Capacity 1	13,9	3,2	0,1	13,9	3,1	0,1
820/820EC	655	Capacity 1	3,6	4,6	0,2	3,6	4,5	0,3
1020/1020 EC	840	Capacity 1	10,4	8,5	0,2	10,4	8,3	0,3
1520/1520 EC	1270	Capacity 1	18,4	11,0	0,3	18,4	10,9	0,5
2020/2020 EC	1560	Capacity 1	16,6	13,9	0,3	16,7	13,7	0,5
2520/2520 EC	2200	Capacity 1	17,5	19,3	0,2	17,5	19,1	0,4
3020/3020 EC	2560	Capacity 1	21,7	21,4	0,3	21,7	21,1	0,5
3520/3520 EC	3175	Capacity 1	29,9	24,5	0,4	29,9	24,0	0,7
5020/5020 EC	4000	Capacity 1	27,6	32,5	0,6	27,6	31,7	1,0
6020 EC	6040	Capacity 1	45,9	29,4	0,2	45,9	28,3	0,3

■ Duct Type Coil Dimensions

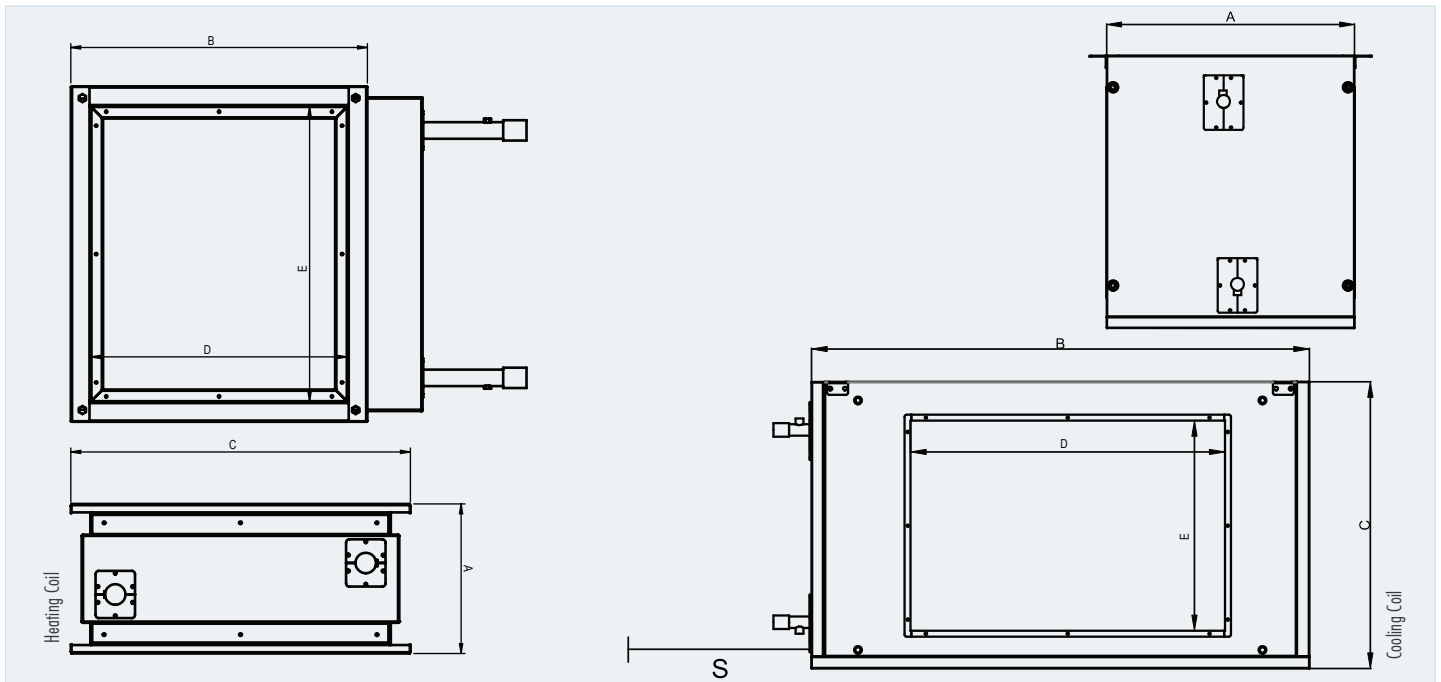

Unit Model	Duct Type Coil Box Model	A	B	C	D	E	S
EVHR 420 EC	Heating Coil-Capacity 1	190	311	332	260	280	311
	Dx Coil-Capacity 1	450	510	490	270	270	510
	Change-Over Coil-Capacity 1	450	510	490	270	270	510
	Change-Over Coil-Capacity 2	450	510	490	270	270	510
	Change-Over Coil-Capacity 3	450	610	540	370	320	610
EVHR 820/820EC	Heating Coil-Capacity 1	190	381	431	330	380	381
	Dx Coil-Capacity 1	450	860	640	620	420	860
	Change-Over Coil-Capacity 1	450	510	490	270	270	510
	Change-Over Coil-Capacity 2	450	510	490	270	270	510
	Change-Over Coil-Capacity 3	450	860	640	620	420	860
EVHR 1020/1020 EC	Heating Coil-Capacity 1	190	381	431	330	380	381
	Dx Coil-Capacity 1	450	860	640	620	420	860
	Change-Over Coil-Capacity 1	450	450	610	540	370	320
	Change-Over Coil-Capacity 2	450	860	640	620	420	860
	Change-Over Coil-Capacity 3	450	450	610	540	370	320
EVHR 1520/1520 EC	Heating Coil-Capacity 1	190	481	481	430	430	481
	Dx Coil-Capacity 1	450	860	640	620	420	860
	Change-Over Coil-Capacity 1	450	610	540	370	320	610
	Change-Over Coil-Capacity 2	450	860	640	620	420	860
	Change-Over Coil-Capacity 3	450	860	640	620	420	860
EVHR 2020/2020 EC	Heating Coil-Capacity 1	190	481	481	430	430	481
	Dx Coil-Capacity 1	450	1060	640	700	420	1060
	Change-Over Coil-Capacity 1	450	860	640	620	420	860
	Change-Over Coil-Capacity 2	450	860	640	620	420	860
	Change-Over Coil-Capacity 3	450	1200	690	900	470	1200
EVHR 2520/2520 EC	Heating Coil-Capacity 1	190	711	581	660	530	711
	Dx Coil-Capacity 1	450	1200	690	900	470	1200
	Change-Over Coil-Capacity 1	450	1060	640	700	420	1060
	Change-Over Coil-Capacity 2	450	1200	690	900	470	1200
	Change-Over Coil-Capacity 3	450	1300	840	1000	620	1300

\* All measurement values are mm.

Unit Model	Duct Type Coil Box Model	A	B	C	D	E	S
EVHR 3020/3020 EC	Heating Coil-Capacity 1	190	711	581	660	530	711
	Dx Coil-Capacity 1	450	1200	690	900	470	1200
	Change-Over Coil-Capacity 1	450	1060	640	700	420	1060
	Change-Over Coil-Capacity 2	450	1300	840	1000	620	1300
	Change-Over Coil-Capacity 3	450	1300	840	1000	620	1300
EVHR 3520/3520 EC	Heating Coil-Capacity 1	190	711	581	660	530	711
	Dx Coil-Capacity 1	450	1200	690	900	470	1200
	Change-Over Coil-Capacity 1	450	1200	690	900	470	1200
	Change-Over Coil-Capacity 2	450	1300	840	1000	620	1300
	Change-Over Coil-Capacity 3	450	1300	840	1000	620	1300
EVHR 5020/5020 EC	Heating Coil-Capacity 1	190	711	581	660	530	711
	Dx Coil-Capacity 1	450	1300	840	1000	620	1300
	Change-Over Coil-Capacity 1	450	1200	690	900	470	1200
	Change-Over Coil-Capacity 2	450	1300	840	1000	620	1300
	Change-Over Coil-Capacity 3	450	1300	840	1000	620	1300
EVHR 6020 EC	Heating Coil-Capacity 1	190	711	581	660	530	711
	Dx Coil-Capacity 1	450	1300	840	1000	620	1300
	Change-Over Coil-Capacity 1	450	1300	840	1000	620	1300

\* All measurement values are mm.

## ■ Ventilation on Demand

Air Quality Sensor (CO<sub>2</sub> / Humidity) is mounted to the return air duct and is connected to control system of unit. The set point for the desired indoor air quality is set during the installation. According to the demand indoors, ENVU-ECO units are modulated automatically by the sensor. Annual energy consumption of the unit is reduced as a result of the modulation, ending in reduction in energy costs.

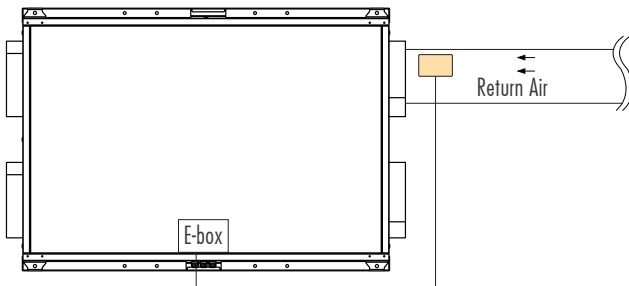

Fresh air demand in a space is calculated according to human occupancy and/or physical properties of the conditioned space. The calculation is based on the maximum indoor occupancy. In practice maximum occupancy is observed for only a small period of time annually where lower air flow rates will be sufficient for most of the year. By reducing the air flow rate according to the fresh air demand; it is possible to reduce units electrical consumption and reduce also energy consumption used to condition the space. It should be noted that by increasing fresh air rate, indoors heating/cooling demand will also be increased.

With the help of control panel, it is possible to regulate fresh air rate according to the demand indoors. Eneko Indoor air quality sensor (CO<sub>2</sub>/Humidity) sensor is mounted to the return duct or the conditioned space and the demanded condition is set. A 0-10 V signal will be created and EVHR unit's air flow will be regulated according to the signal.

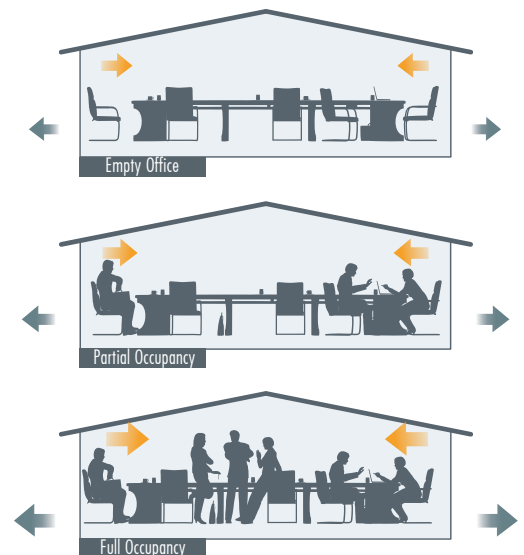



## SHIPMENT

Shipment is made for the buyer's account. Mode of shipment and shipping route, transport and packaging and other securities respectively shall be at our choice. We shall be entitled, however, not obliged to insure deliveries in the name and for account of the buyer. Risk passes to the buyer when shipment is handed over to the person performing the transport or left our Works for shipment. If shipment is delayed upon buyer's request, risk passes to the buyer with the ready for shipment note. If ordered goods are rejected after the ready for shipment note, we shall be entitled to request payment and store the goods at buyer's expense. Discharge of the goods is made at buyer's expense.



## RETENTION OF TITLE

In any event ENEKO shall retain full ownership of all materials supplied whilst the payment conditions of the entire amount have not been complied with, said materials may be removed from the customer at our request. Should the customer be declared bankrupt or insolvent and has not made paid the entire amount of payments. ENEKO shall be entitled to recover the goods. ENEKO may interrupt the supply without incurring any liability whatsoever if he had notice of or became aware of a decrease in the creditworthiness of the purchaser or if any of the existing negotiable instruments or debts were not properly complied with, shall result as being unpaid and protested.



## WARRANTY

ENEKO Products are under warranty (defect in material or workmanship) for 2 years from the date of sale reflected on the invoice. Under this warranty, ENEKO is under the obligation to replace the part requested under warranty.

The followings are excluded from ENEKO warranty:

- Normal wear and tear
- Defective assembly or handling
- Third party compensation

Parts the subject of a claim shall be sent to our warehouse as carriage paid with relevant report completely filled in, wherein the parts shall be subjected to analysis.



## LIABILITY

ENEKO, for any losses/damages, shall only be responsible within the limits of the law. Owing to basic obligations undertaken by simple negligence, if the contract is violated, ENEKO's liability shall be limited to compensate for losses which are emerged specific and predictable. ENEKO shall not carry any responsibility in case of a single negligence in breach of non-essential contractual obligations.



## PROPERTY RIGHTS

The purchaser in no event and under no circumstances whatsoever shall publish or use the trademark, trade name or logo of ENEKO without a prior written permission.



## GOVERNING LAW AND JURISDICTION

This agreement shall be governed with all aspects of the Turkish Law. The courts of Izmir/Turkey shall have an exclusive jurisdiction to adjudicate any dispute arising under or in connection with this agreement.



## GENERAL

The sale of all Products of ENEKO shall exclusively be made on the basis of these General Terms and Conditions of Sales. Any other conditions and General Conditions of Purchase of the Buyer are not accepted.



## OFFERS

Our offers are non-binding and without obligation. Contracts for delivery and all other agreements (including subsidiary agreements) as well as declarations of our representatives shall only become legally binding for us after written confirmation. We do not render planning service.

Proposals made and information provided by our representatives shall be non-binding. Illustrations, drawings, dimensions and weights or other performance data shall only be binding if this is expressly agreed in writing.



## TERMS OF ORDER

Purchase orders shall be sent to ENEKO in written form and shall be non-binding unless they are accepted by written confirmation (order confirmation) from ENEKO. Each order shall include properly identified Products ordered and relevant shipping dates.



## PRICE OF THE GOODS

Prices are net Ex Works according to current Incoterms unless stated otherwise and do not include any kind of taxes. Prices are valid at the date of delivery will be applied. We reserve the right to adjust prices for confirmed orders as well to reflect any increase in our costs for any reason beyond our control like force majeure, shortage of primary material or labor strikes, official orders, transportation or similar problems. In this case, a new price agreement shall be required for higher rates. If such an agreement is not made, we shall be entitled to withdraw from the contract by written notice within 15 days.



## TERMS OF PAYMENT

Payments shall be carried out according to the contractual terms as defined and set forth in the order confirmation. If the payment conditions have not been agreed upon conclusion of the contract, the payment terms and payment dates specified in our invoices shall be binding. Deadlines for discounts and periods allowed for payment shall begin to run upon receipt of the invoice. Payments by draft, bills of Exchange or anyway extended payments shall mean neither credit novation, nor prejudice to the Retention of Title agreement, nor to territorial competence. If buyer fails to make payment by due date, we are entitled to charge the buyer with a relevant interest on the unpaid amount.



## TERMS OF DELIVERY

Delivery time information is only approximate. We shall only be in default if the performance is due and a written demand for payment was issued. Delivery day is the day of dispatch Ex Works. We shall also not be liable with regard to bindingly agreed periods and dates in the event of delays on delivery and of performance due to force majeure and events which considerably complicate or make delivery impossible not only temporarily-strike lockout, breakdown, delay in supply with important raw and auxiliary materials even if the delay occurs at our supplier, in particular. These delays entitle us to postpone delivery for the period of the impediment plus a reasonable start-up period or to withdraw from the contract as a whole or in part. If delivery time is extended or we are released from our delivery commitment, the buyer may not derive a claim for damages from it. However, we may only rely on the circumstances mentioned if we notify the buyer immediately. We shall be entitled to make part deliveries. Any part delivery shall be considered as independent transaction. In case of default, our liability is limited to contract-typical foreseeable damage.



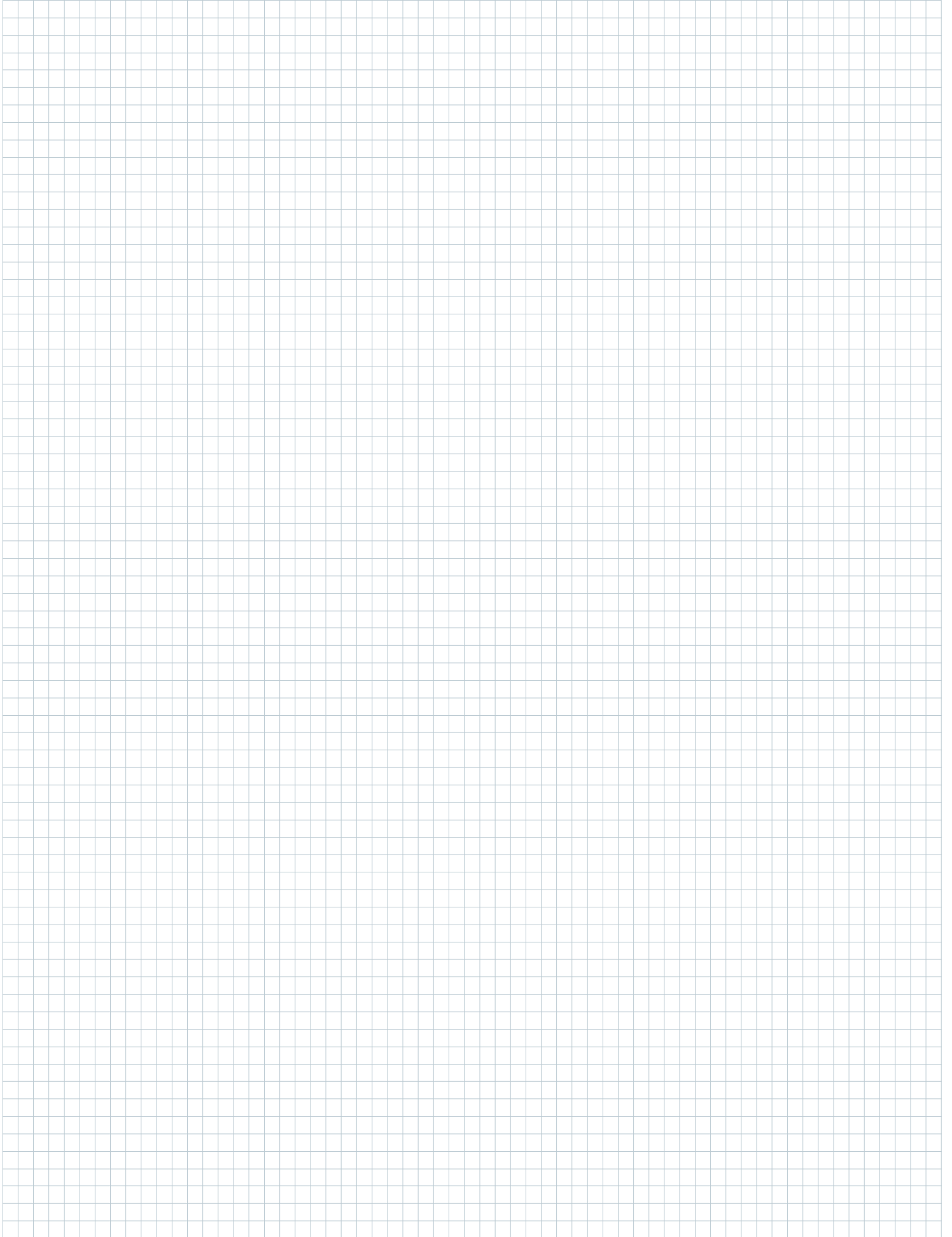





#### ISTANBUL

**Address** : Cevizli District, Zuhal Avenue, Fusun Street, Ritim Istanbul A5  
Block Floor: 25 No: 137, 34846 Maltepe/Istanbul - TURKEY  
**Tel.** : +90 216 455 29 60 / +90 216 455 29 61  
**Fax.** : +90 216 455 29 62  
**E-mail** : satis@eneko.com.tr

#### IZMIR

**Address** : 10049 Street No: 4 I.A.O.S.B. Cigli/Izmir - TURKEY  
**Tel.** : +90 232 328 20 80  
**Fax.** : +90 232 328 20 22  
**E-mail** : info@eneko.com.tr  
**Web** : www.eneko.com.tr

In parallel with our ongoing product development in R&D department, all rights of changing all technical specifications are reserved by ENEKO without any declaration and notice.

