



**CEILING TYPE
HEAT
RECOVERY
UNITS**

ENVU-ECO Series









New compact ceiling type unit range is designed to meet ventilation demand for various commercial spaces and for all budgets while still keeping high level of Eneko quality. With ceiling-mounted installation, it eliminates the need for mechanical space, significantly expanding commercial living areas.

Compact Design

Designed to seamlessly integrate into the building, it requires minimal space, making it an ideal solution for space-constrained environments.

Easy Control

Easy installation, seamless integration with existing systems, quick connection, and full control. Manage anytime with remote access.

 LOW ENERGY CONSUMPTION	 PLUG&PLAY	 COMPACT	 LOW NOISE	 UP TO 85% ENERGY EFFICIENCY	 EASY INSTALLATION	 LOW SERVICE COST
------------------------------------------------------------------------------------------------------------------	--------------------------------------------------------------------------------------------------	------------------------------------------------------------------------------------------------	--------------------------------------------------------------------------------------------------	-----------------------------------------------------------------------------------------------------------------------	---------------------------------------------------------------------------------------------------------------	--------------------------------------------------------------------------------------------------------------

www.eneko.com.tr

Factory: 10049 St. No: 4 I.A.O.S.B. Cigli/Izmir - Turkiye - 0232 328 20 80 - 0232 328 20 22 - export@eneko.com.tr

Istanbul Sales Office: Cevizli District, Zuhul Avenue, Fusun St., Ritim Istanbul A5 Block Floor: 25 No: 137, 34846 Maltepe/ Istanbul - Turkiye 0216 455 29 60 - 0216 455 29 61 - 0216 455 29 62 - satis@eneko.com.tr



TECHNICAL SPECIFICATIONS

Unit type	400	700	1200	1500	2200	2500
ERP	Yes					
Heat recovery (EN 308)	Yes					
Heat recovery efficiency (%) (-5%80)	>85					
Max. air flow range (m ³ /h) (at 0 Pa)	500	725	1.220	1.620	2.300	2.650
Max. air flow range (m ³ /h) (at 150 Pa)	440	610	1.040	1.400	2.070	2.390
Nominal external pressure (Pa)	150	150	150	150	150	150
Unit Voltage (V)	230	230	230	230	400	400

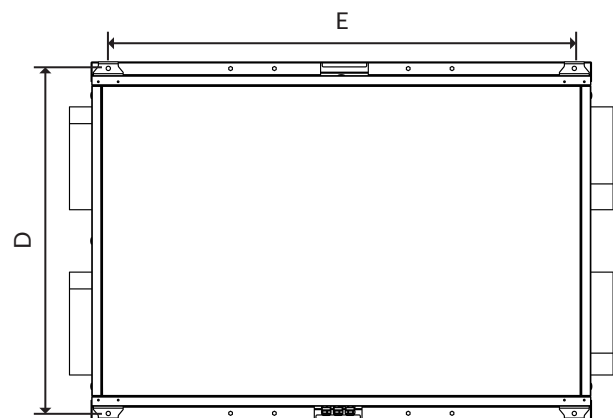
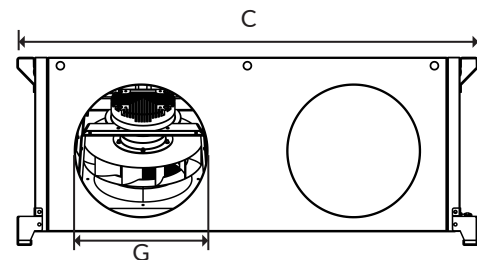
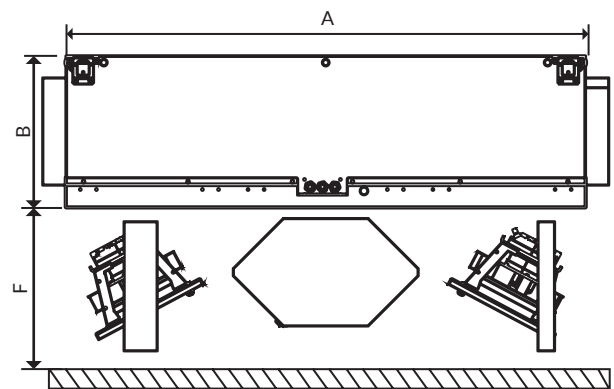
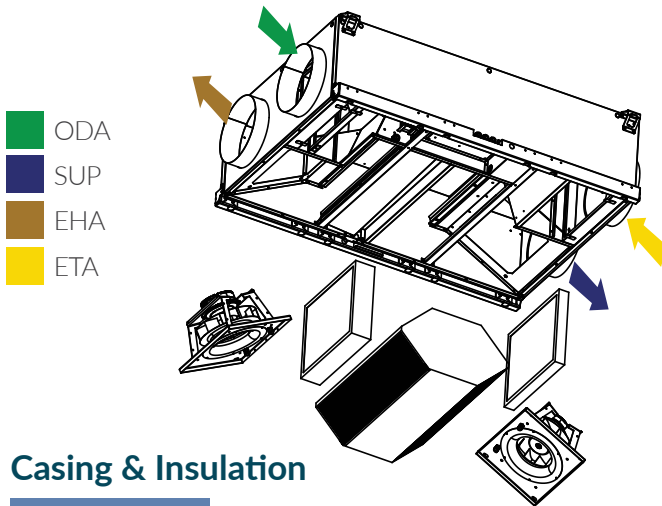

Casing & Insulation

- 30 mm rockwool insulation
- High corrosion resistant 200 gr/m² galvanized steel
- Low unit height for easy mounting
- All services from bottom with sliding panel system

Fan

- EC motor plug fans with high aerodynamic efficiency, low noise levels and energy consumption

Filter

- Standard ePM1 50% (F7) class filters on the fresh air side and ePM10 50% (M5) filters on the exhaust side
- Use of integrated optional ePM1 80% (F9) filter

Heat Exchanger

- Counterflow heat recovery exchanger that can reach 83% at nominal flow rates
- By-pass damper for free cooling and deicing functions

	A	B	C	D	E	F	G (Ø)
400	1310	290	783	744	1210	522	200
700	1410	380	1083	1044	1310	621	250
1200	1510	440	1083	1044	1410	662	300
1500	1510	440	1287	1250	1410	662	315
2200	1760	500	1287	1250	1660	744	355
2500	1760	500	1587	1550	1660	744	355