

# EVER

Ceiling Type Energy Recovery Unit



Index

EVER  
Ceiling Type High Efficient Heat Recovery Unit

- Unit Components 2
- Performance Data 3
- Technical Specifications 7
- Unit Dimensions 7
- Service Space & Installation 7
- Working Principle of Unit 8
- Control System 9

Accessories

- Duct Type Electric Heaters 11
- Ventilaton on Demand 11
- Sound Attenuator For Circular Ducts 12
- Duct Type Coils 12

General Terms and Conditions of Sale 13

**Casing & Insulation**  
High corrosion resistive 200 gr/m<sup>2</sup> galvanize coated steel is used for the casing. Inside of outdoor air is 10 mm, outside of outdoor air is 5 mm; inside of indoor air is 10 mm insulated with non-flammable acoustics insulation material against sound and thermal conduction.

**By-Pass System**  
EVER units have by-pass ventilation system. In transition seasons like spring, autumn and also at nights in summer or at same outdoor air conditions, by-pass damper opens, deactivate the heat exchanger and provides free-cooling. Control of by-pass damper with ENECON control, is done depending on outdoor air temperature, indoor air temperature and set temperature. EVER 3000 and EVER 4000 units haven't by-pass system.

**Cellulosic Paper Type Heat Exchanger**  
EVER energy recovery ventilation units have cellulosic crossflow, high efficient plate heat recovery exchangers. The exchanger transfers sensible heat and moisture between supply and exhaust air. Thus, it is also possible to transfer latent heat. With the optimization of heat exchanger, temperature and humidity efficiency is increased, pressure drop is decreased. Cellulosic paper type crossflow heat exchanger prevents decreasing moisture in winter time and increasing moisture in summer time. It helps indoor air quality to be increased.

**Filters**  
To increase indoor air quality and to protect the equipments used in unit, G class filters (according to EN 779 standard) are used for both exhaust and supply air streams. F class filters can be also used optionally. F class filters reduce the available static pressure of the unit for the nominal air flow rate.

**Control System**  Plug&Play  
ENECON control unit is developed for controlling of heat recovery units' equipments, meeting the demands coming from the customers and is user friendly designed. ENECON is capable of controlling the standard equipments and optional accessories. ENECON Control unit can perform the basic functions without any control panel; it is more functional used with Basic and Pro-Panel. Besides, the control unit can switch on/off via BMS, gets fault signal and controls all the functions via ModBus. Alternatives different from Enecon controller are listed in "Control System" part.

**Supply and Exhaust Air Fans**  
Backward curved plug fans are used in EVER units. Fan blades have high aerodynamic efficient backward curved design. Plug fans are used for high efficiency and low sound levels. With AC Fans it is also possible to reduce maintenance costs as the fans are direct drive; free of belt and pulley.

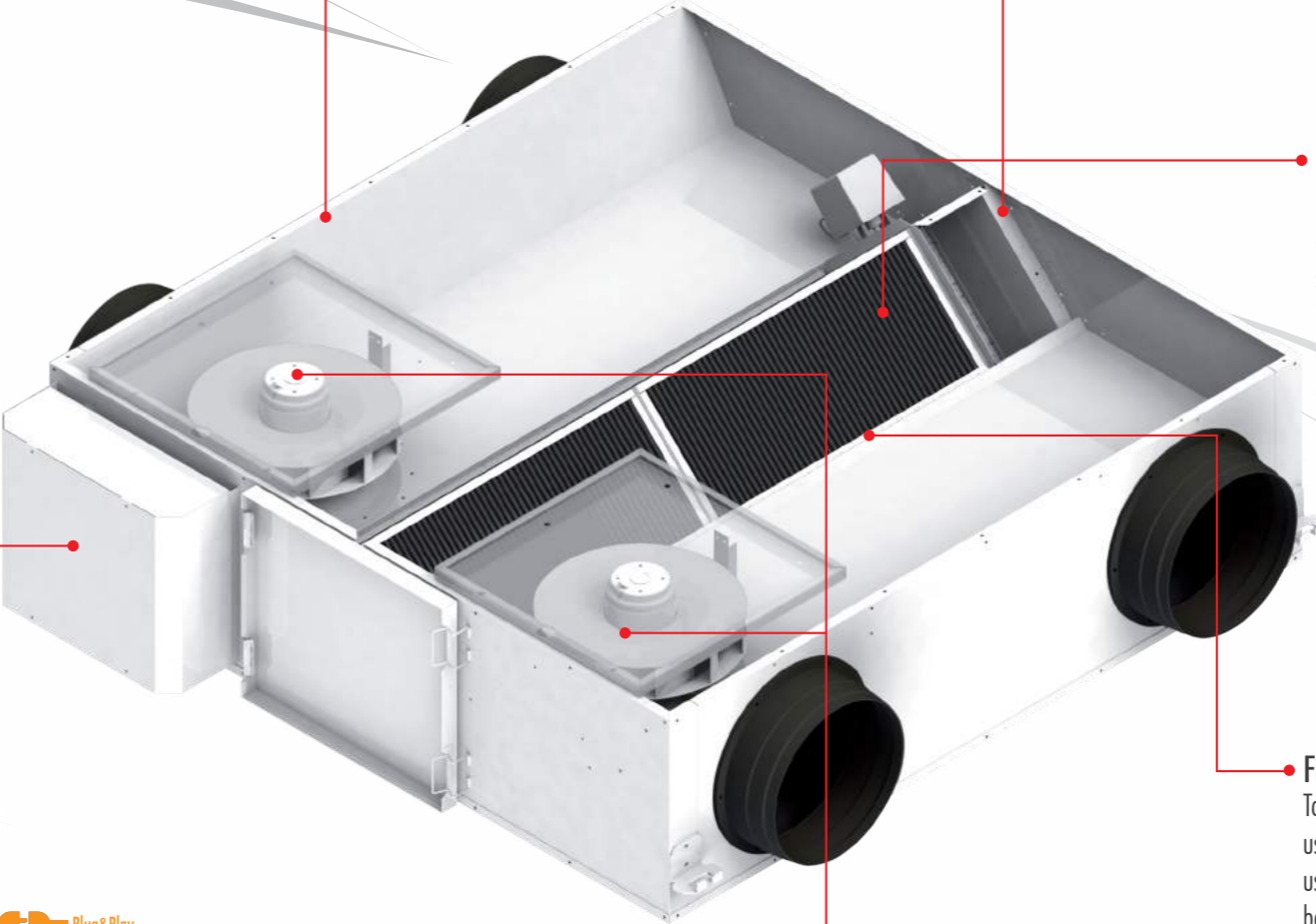

 The technical specifications and the performance data declared with this logo have been developed by the tests performed in Eneko Energy Laboratory which is established with the development Project support of Tübitak by regarding relevant standards.

## EVER 325

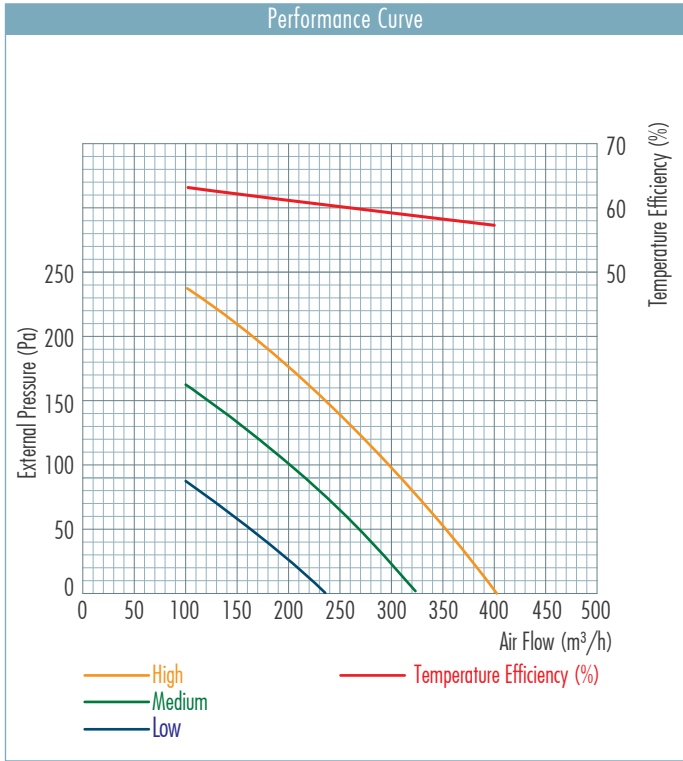

## EVER 650

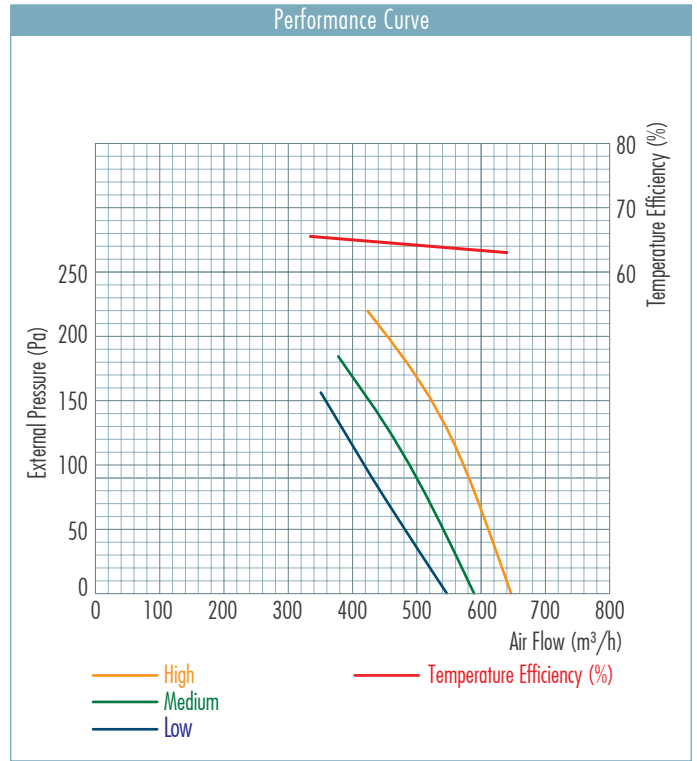

## EVER 650

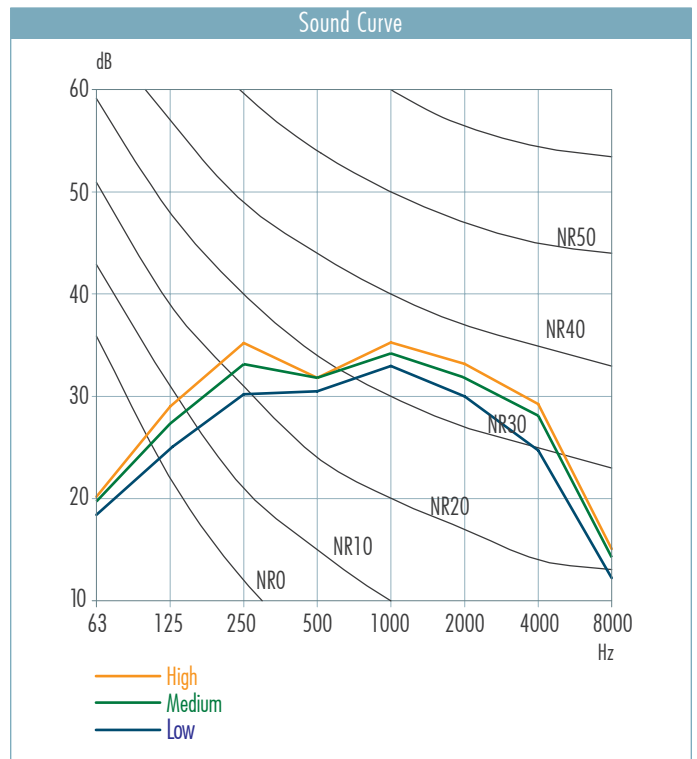

Note: Efficiency values are calculated according to EN 308 standard.

## EVER 1000

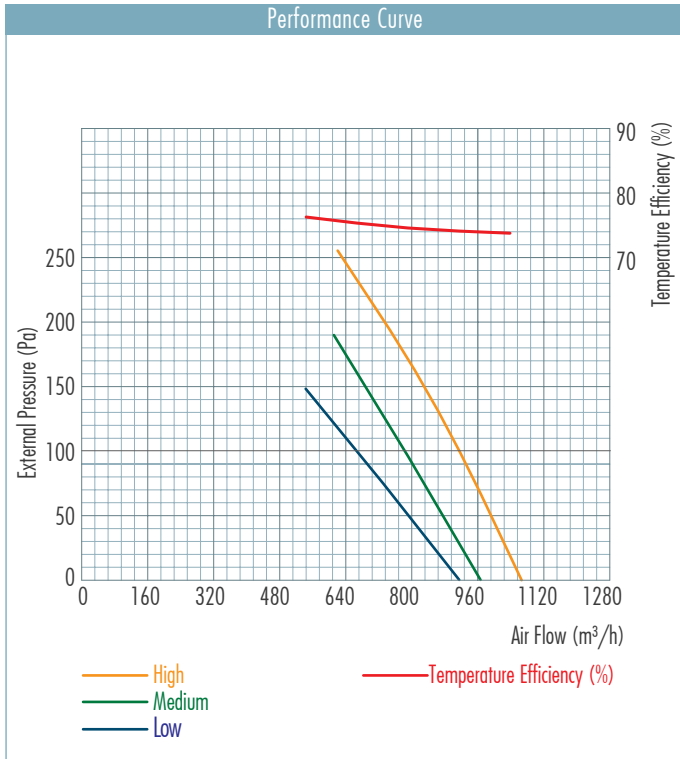

## EVER 1500

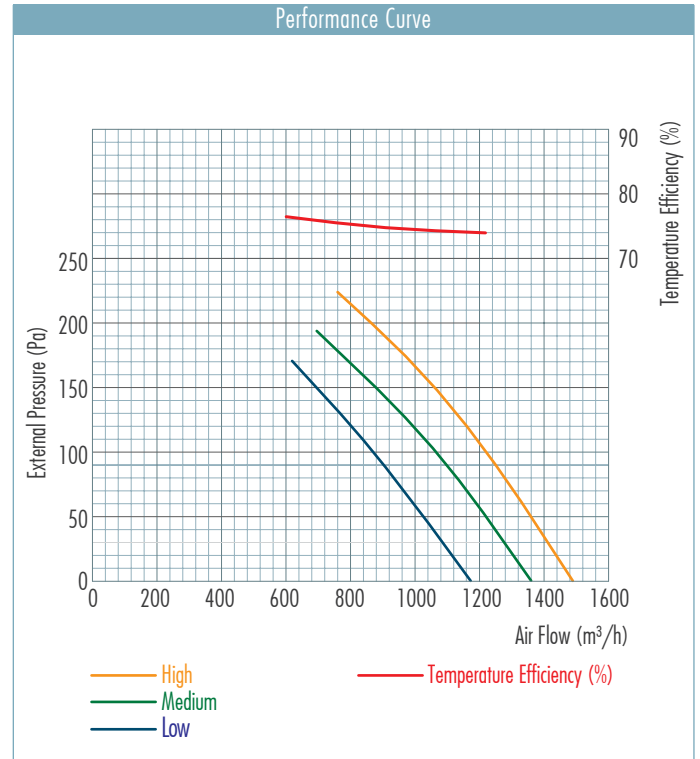

## EVER 1000

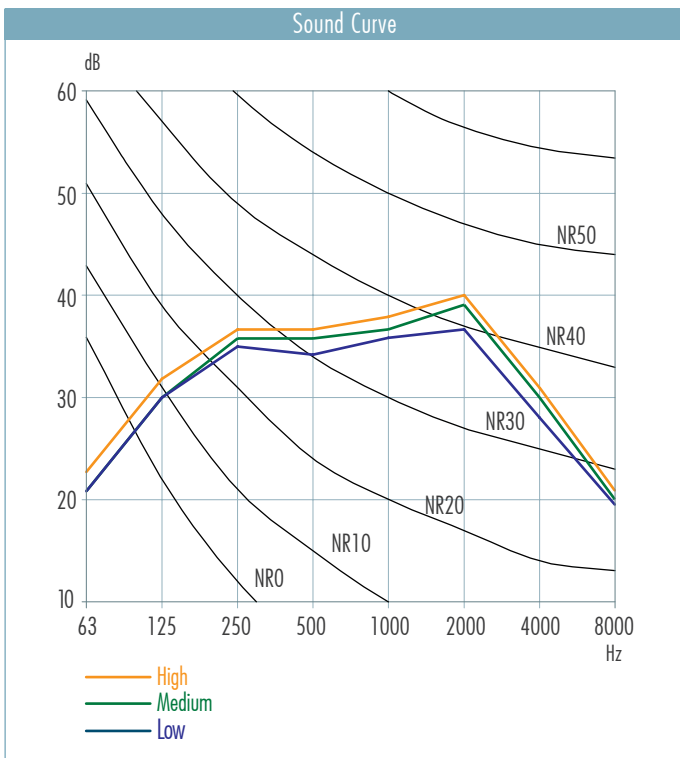

## EVER 1500

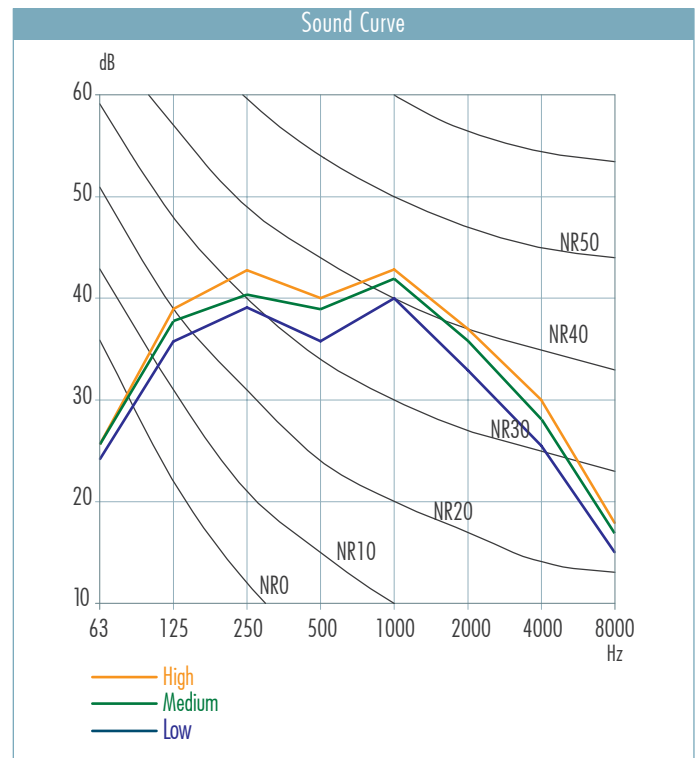

Note: Efficiency values are calculated according to EN 308 standard.

# Performance Data

## EVER 2000

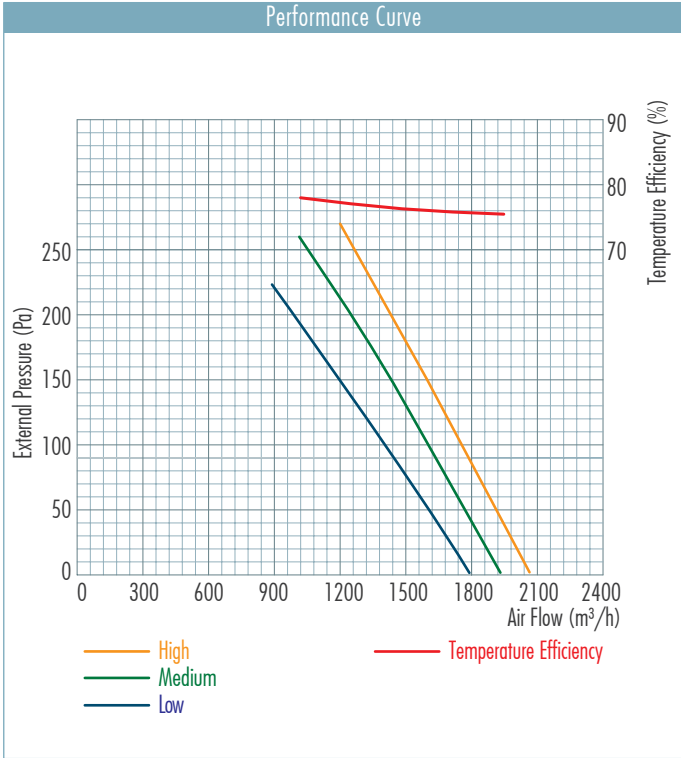

## EVER 2500

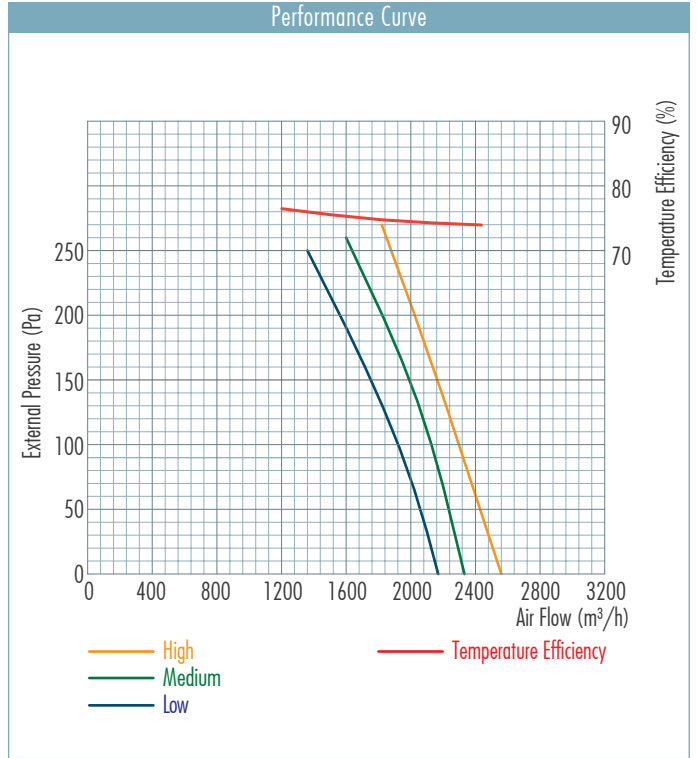

## EVER 2000

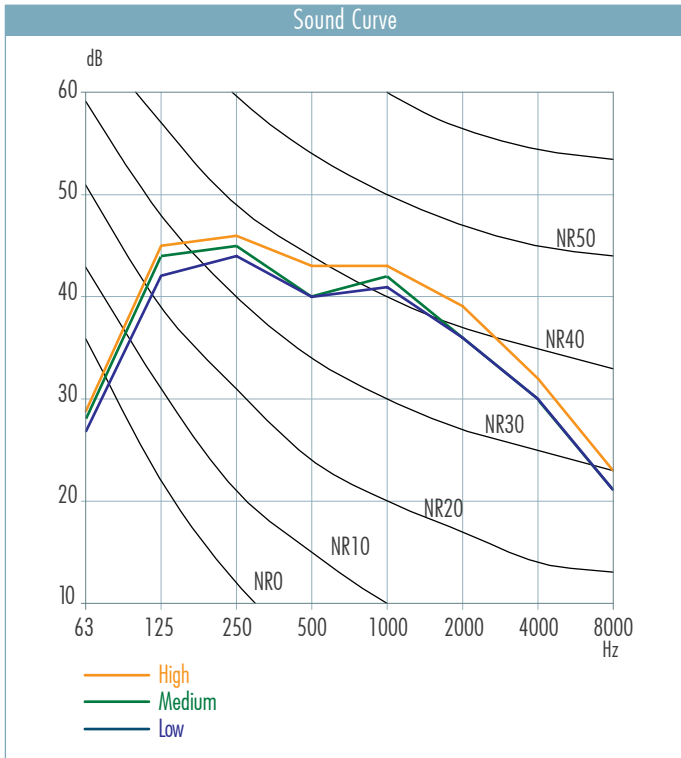

## EVER 2500

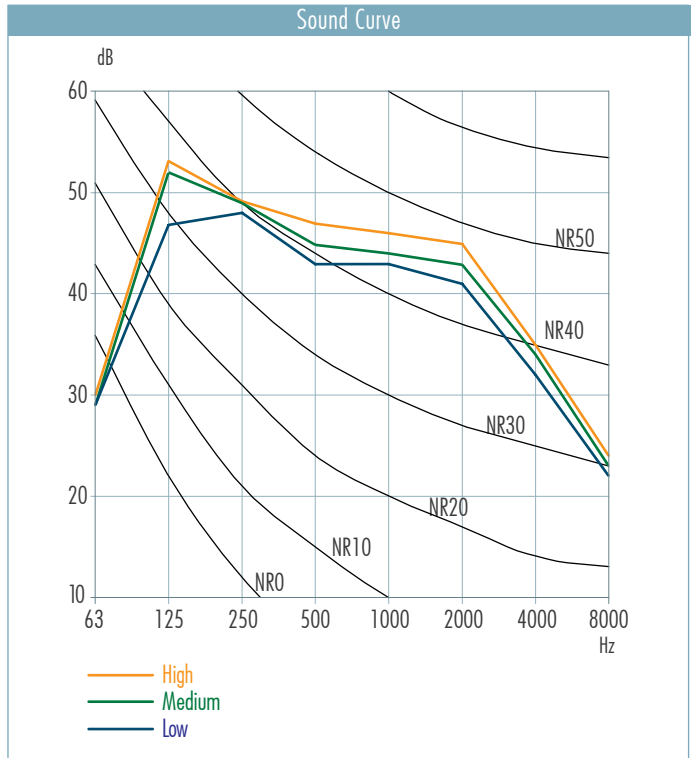

**Note:** Efficiency values are calculated according to EN 308 standard.

## EVER 3000

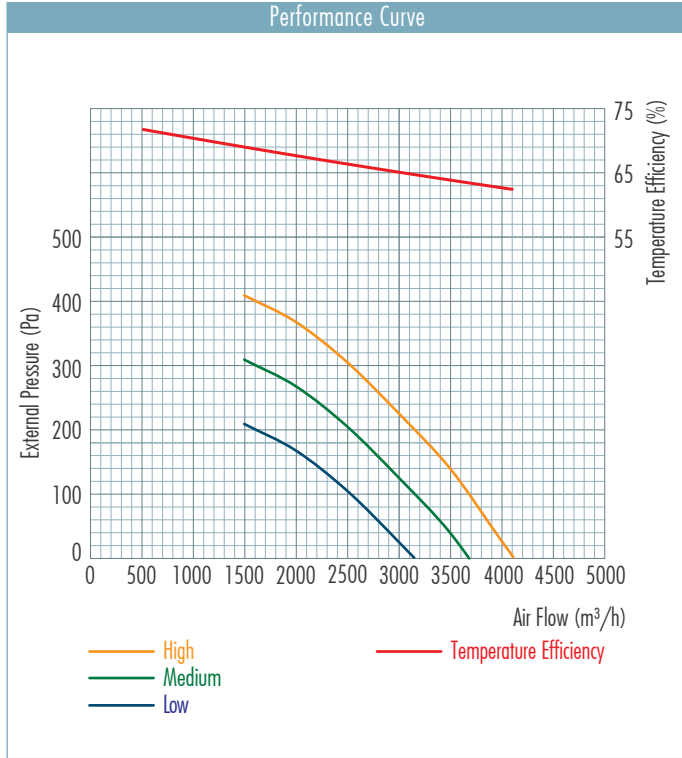

## EVER 4000

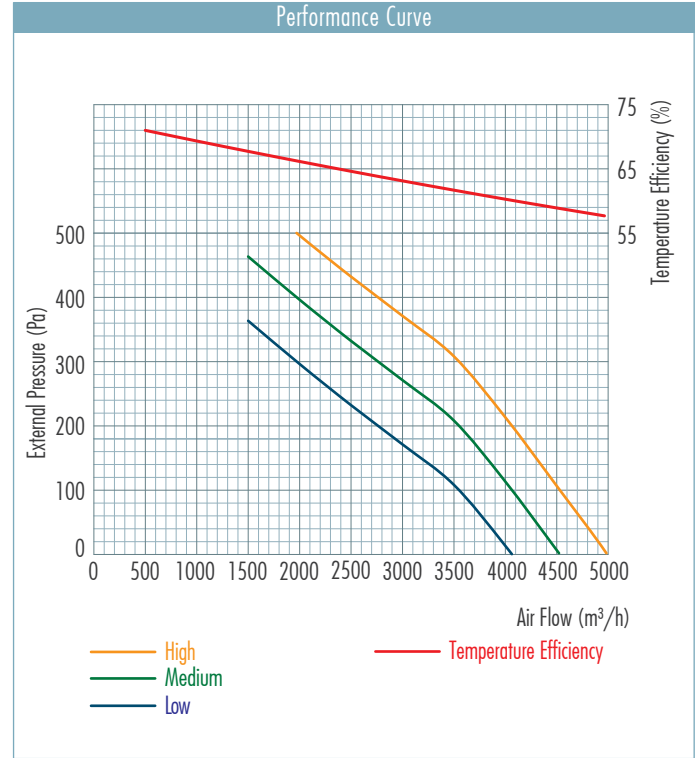

**Note:** Efficiency values are calculated according to EN 308 standard.

# Technical Specifications & Unit Dimensions

		EVER 325	EVER 650	EVER 1000	EVER 1500	EVER 2000	EVER 2500	EVER 3000	EVER 4000		
EVER TECHNICAL SPECIFICATION	Air Flow*	m <sup>3</sup> /h	400	640	1060	1480	2050	2550	4100	5000	
	Supply Voltage	V/Hz/ph	230/ 50 /1~								
	Max. Power Consumption	W	96	204	310	450	450	1030	1420	2600	
	Operation Current	A	0.44	0.9	1.36	2	2	4.5	6	11.6	
	Max. Sound Pressure**	dB	35	36	36	41	45	49	50	52	
	Unit Weight	kg	36.5	50	84	102	118	122	225	280	
	Filter Class		G Class Synthetic Filter According to EN 779								

\*External static pressure is 0 Pa.

\*\*Measured at 1,5m distance to the unit @ 250 Hz.

## EVER Unit Dimensions

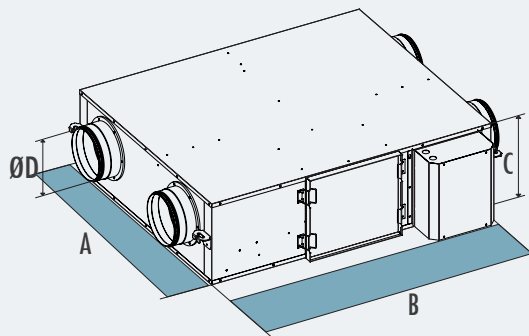

	EVER 325	EVER 650	EVER 1000	EVER 1500	EVER 2000	EVER 2500	EVER 3000	EVER 4000
<b>A</b>	758	665	925	1175	1125	1425	1570	1651
<b>B</b>	985	1130	1130	1150	1650	1650	2200	2200
<b>C</b>	275	330	330	330	440	440	587	650
<b>ØD</b>	160	200	250	250	300	355	500x400 800x400	550x450 800x450

\*All measurement values are mm.

## Service Space & Installation

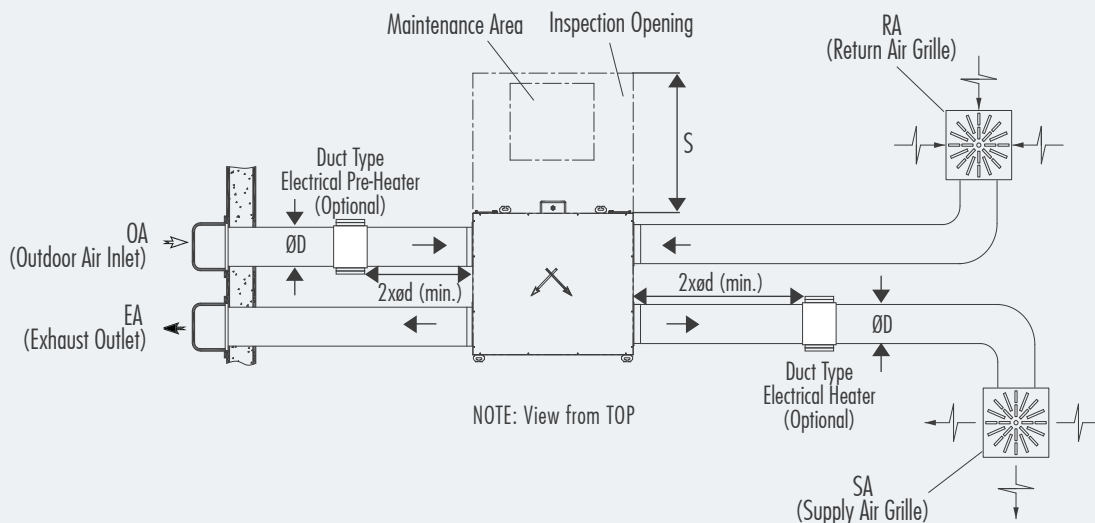

	EVER 325	EVER 650	EVER 1000	EVER 1500	EVER 2000	EVER 2500	EVER 3000	EVER 4000
<b>S</b>	700	600	600	600	700	700	1100	1100

"S" value indicate the size of the service area.

A service space of "C" must be left under the unit for fan service.

\*All measurement values are mm.

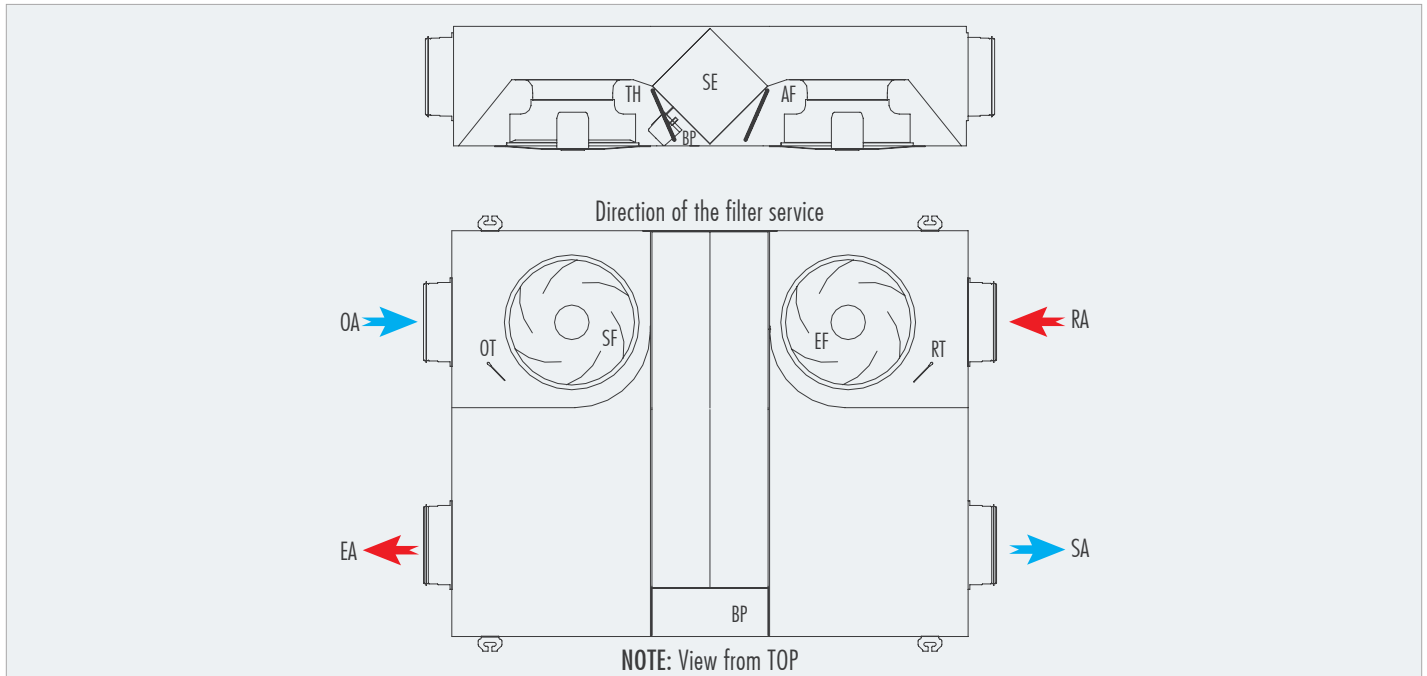

## Descriptions:

SA - Supply Air

BP - By-Pass Damper

RT - Return Air Temperature Sensor

RA - Return Air

SF - Supply Air Fan

AF - Exhaust Air Filter

EA - Exhaust Air

OT - Outdoor Air Temperature Sensor

SE - Cellulosic Exchanger

OA - Outdoor Air

EF - Exhaust Air Fan

TH - Fresh Air Filter

## ■ Cellulosic Exchanger



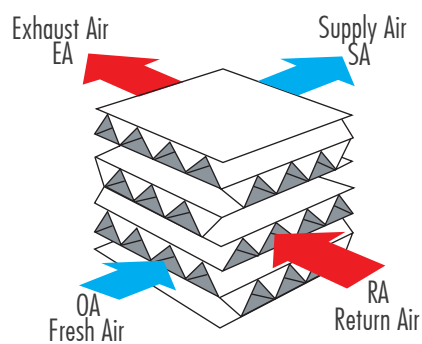



- High Efficiency Sensible & Latent Enthalpy Transfer
- Humidity Transfer
- Up to 20% Reduction in cooling load
- Sound absorbing material





Automation Options		Control Cards						
Standard	Optional	Standard Basic	Standard Pro	Alternative 1	Alternative 2	Alternative 3		
						Type 1	Type 2	Type 3
OA Temperature Sensor		✓	✓	✓	✓	✓	✓	✓
RA Temperature Sensor		✓	✓	✓	✓	✓	✓	✓
SA Fan Control		✓	✓	✓	✓	✓	✓	✓
RA Fan Control		✓	✓	✓	✓	✓	✓	✓
ByPass Damper		✓	✓	✓	✓	✓	✓	✓
Filter Contamination Info (Time)		✓	✓	✓	✓	✓	✓	✓
Modbus RTU		✓	✓	✗	✓	✓	✓	✓
	On/Off Damper Control	✓	✓	✗	✓	✓	✓	✓
	Proportional Damper Control	✗	✗	✗	✓	✓	✓	✓
	Airflow Control			✗	✓		✓	
	Humidity Control	☉	☉	✓	✓	☉	✓	☉
	CO2 Control			✓	✓		✓	
	SA Temperature Sensor	✓	✓	✓	✓	✓	✓	✓
	On/Off Heating Coil	✓	✓	✗	✓	✓	✓	✓
	Proportional Heating Coil	✗	✗	✗	✓	✓	✓	✓
	On/Off Cooling Coil	✓	✓	✗	✓	✓	✓	✓
	Proportional Cooling Coil	✗	✗	✗	✓	✓	✓	✓
	Electrical Pre-Heater	✓	✓	✗	✓	✓	✓	✓
	Electrical After-Heater	✓	✓	✗	✓	✓	✓	✓
	BacNET MSTP	✗	✗	✗	✓	✓	✓	✓
	Web Browser (TCP/IP)	✗	✗	✗	✓	✗	✓	✗
	Weekly Timer	✗	✓	✗	✓	✓	✓	✓
	Filter Contamination Info (DPS)	✓	✓	✓	✓	✓	✓	✓

☉ Only one of them of defined functions is selectable for this control card.

Control Panel		Control Cards						
Panel Type	Panel Descriptions	Standard Basic	Standard Pro	Alternative 1	Alternative 2	Alternative 3		
						Type 1	Type 2	Type 3
	Standard-Basic Wall-mounted type Max:30 m communication ability	✓	✗	✗	✗	✗	✗	✗
	Standard-Pro Wall-mounted type Max:50 m communication ability	✗	✓	✗	✗	✗	✗	✗
	Alternative-1 Wall-mounted type Wireless Radio Frequency (RF) panel Max:50 m communication ability	✗	✗	✓	✗	✗	✗	✗
	Alternative-2 Wall-mounted type hand panel, IP 30 protection class, Max:100 m communication ability	✗	✗	✗	✓	✗	✗	✗
	Alternative-3.1 Wall-mounted type room panel, IP 30 protection class, Max:700 m communication ability	✗	✗	✗	✗	✗	✗	✓
	Alternative-3.2 <b>Hand Panel 1:</b> Wall-mounted type, IP 65 protection class for only front side of panel, Max:50 m communication ability <b>Hand Panel 2:</b> Magnet type, IP 65 protection class for whole panel, Max:50 m communication ability	✗	✗	✗	✗	✓	✓	✓
	Alternative-3.3 Magnet type, IP 31 protection class, Max:700 m communication ability	✗	✗	✗	✗	✓	✓	✓

## ■ Selection of Electrical Cable Cross-Section

### Electrical Cable Selection of Heat Recovery Unit - 230V 1 phase

Unit Model	Unit Power Input (W)	Fuse (A)	Cable Cross-Section (mm <sup>2</sup> )						
			1.5	2.5	4	6	10	16	
EVER									
325	96	1	244	-	-	-	-	-	-
650	204	2	115	192	-	-	-	-	-
1000	310	2	76	126	-	-	-	-	-
1500	450	3	52	87	139	208	-	-	-
2000	450	3	52	87	139	208	-	-	-
2500	1030	6	-	38	61	91	152	-	-
3000	1420	10	-	28	44	66	110	-	-
4000	2600	16	-	-	24	36	60	96	-

Note: The values given in the table is the length of the cable in meters (m). Cable property: 3 x (phase + neutral + earth).

### Electrical Cable Selection of Electric Heater - 230V 1 phase

Unit Model	Heater Diameter (mm)	Unit Power Input (kW)	Fuse (A)	Cable Cross-Section (mm <sup>2</sup> )					
				1.5	2.5	4	6	10	16
EVER									
325	∅160	1	6	61	102	163	163	-	-
650	∅200	2	16	31	51	82	122	-	-
1000	∅250	3	20	-	34	55	82	136	-
1500	∅250	3	20	-	34	55	82	136	-

Note: The values given in the table is the length of the cable in meters (m). Cable property: 3 x (phase + neutral + earth).

### Electrical Cable Selection of Electric Heater - 400V 3 phase

Unit Model	Heater Diameter (mm)	Unit Power Input (kW)	Fuse (A)	Cable Cross-Section (mm <sup>2</sup> )					
				1.5	2.5	4	6	10	16
EVER									
2000	∅300	5	3 x 16	73	121	194	-	-	-
2500	∅355	7	3 x 16	52	87	139	-	-	-
3000	500x400	8	3 x 16	46	76	121	182	-	-
4000	550x450	10	3 x 20	37	61	97	146	-	-

Note: The values given in the table is the length of the cable in meters (m). Cable property: 4 x (phase1 + phase2 + phase3 + earth).

### ■ Duct Type Electric Heater



Duct type electric heater that is used for reinforcement purpose depending on needs, is produced of stainless steel heating elements and galvanized metal casing. Besides, duct type electric heater is produced stainless sheet body optionally.

Electric heaters are equipped with two excessive temperature protection. When inside of the electric heater's temperature is 70°C, "automatic excessive temperature protection" enables and electric heater disables automatically.

When 70°C automatic temperature protection doesn't enable and the inside of the electric heater's temperature is 110°C, the second protection enables and electric heater disables until the manual reset will be done.

The electrical heaters, designed as maximum 2 steps, step automatically according to temperature that is set on room control panel with control panel. Eneko electric heaters are connected in Delta connection in standard models.

#### Heating Capacity Calculation

$$Q = 0,33 \times V \times (T_2 - T_1)$$

Q : Heating Capacity (W)

V : Air Flow through electric heater (m<sup>3</sup>/h)

T<sub>1</sub> : Air temperature before the heater (°C)

T<sub>2</sub> : Air temperature after the heater (°C)

### ■ Ventilation on Demand

Air Quality Sensor is mounted to the return air duct and is connected to control system of unit. The set point for the desired indoor air quality is set during the installation. According to the demand indoors, EVER units are modulated automatically by the sensor. Annual energy consumption of the unit is reduced as a result of the modulation, ending in reduction in energy costs.

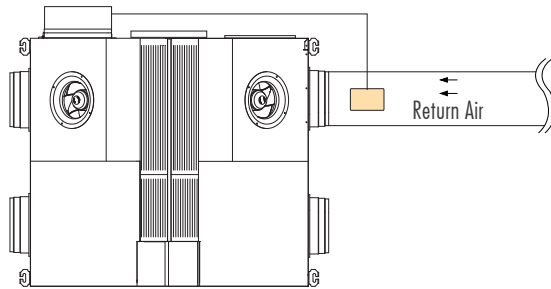

Fresh air demand in a space is calculated according to human occupancy and/or physical properties of the conditioned space. The calculation is based on the maximum indoor occupancy. In practice maximum occupancy is observed for only a small period of time annually where lower air flow rates will be sufficient for most of the year. By reducing the air flow rate according to the fresh air demand; it is possible to reduce units electrical consumption and reduce also energy consumption used to condition the space. It should be noted that by increasing fresh air rate, indoors heating/cooling demand will also be increased.

With the help of control kit of unit, it is possible to regulate fresh air rate according to the demand indoors. Indoor air quality sensor or CO<sub>2</sub> sensor is mounted to the return duct or the conditioned space and the demanded condition is set. A 0-10 V signal will be created and EVER unit's air flow will be regulated according to the signal.

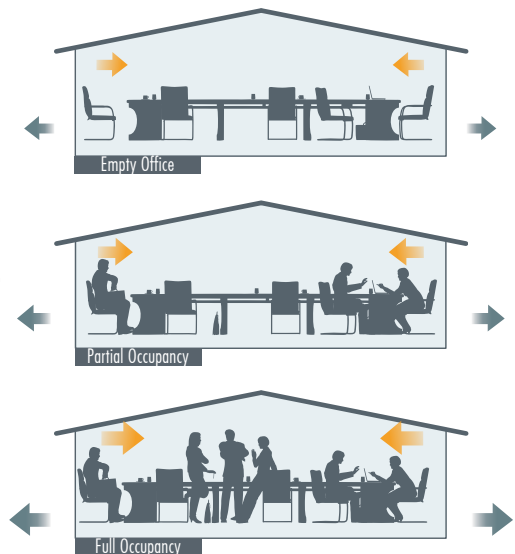

## ■ Sound Attenuator For Circular Ducts



Sound attenuators are designed for standard duct dimensions. Various lengths are available according to attenuation demand. Sound attenuation capacities are given in the table. For better performance sound attenuators can be used in series. For the best result the sound attenuators shall be installed just after the unit.

### Notation

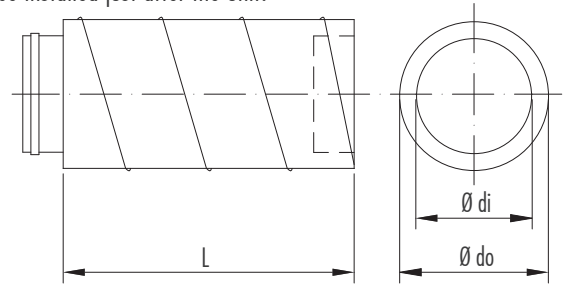
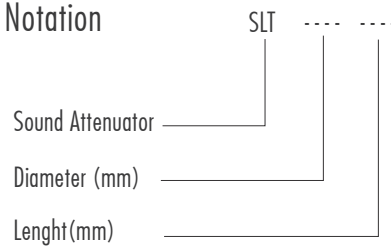

### Sound Attenuator Capacity [dB]

SLT	63	125	250	500	1k	2k	4k	8k
200-300	1	2	3	6	10	14	12	14
200-600	2	3	6	7	13	17	18	20
200-900	3	4	7	10	16	18	21	22
250-300	1	2	6	6	13	16	14	15
250-600	2	3	7	7	18	21	20	22
250-900	3	4	9	8	21	24	21	23
300-300	1	2	4	4	10	12	12	15
300-600	1	3	6	7	13	15	17	19
300-900	2	4	7	8	15	17	18	21
355-600	1	3	8	8	9	6	5	7
355-900	4	4	13	13	11	7	6	8

### Sound Attenuator Dimensions [mm]

SLT	length(L)	Ø di	Ø do
200-300	300	200	260
200-600	600	200	260
200-900	900	200	260
250-300	300	250	310
250-600	600	250	310
250-900	900	250	310
300-300	300	300	360
300-600	600	300	360
300-900	900	300	360
355-600	600	355	415
355-900	900	355	415

## ■ Duct Type Coils



Duct type heating/cooling coils are assembled in cabin as suitable to mount inside duct and have standard capacity. Coils consist of copper tubes and aluminum fins. Inlets and outlets of cabin are suitable for circular duct connections as in heat recovery ventilation units. Additionally, cooling coils have drain pan and extra insulation to prevent condensation of cabin. Both heating and cooling coils can be controlled separately as on/off via unit automation system.



## GENERAL

The sale of all Products of ENEKO shall exclusively be made on the basis of these General Terms and Conditions of Sales. Any other conditions and General Conditions of Purchase of the Buyer are not accepted.



## OFFERS

Our offers are non-binding and without obligation. Contracts for delivery and all other agreements (including subsidiary agreements) as well as declarations of our representatives shall only become legally binding for us after written confirmation. We do not render planning service.

Proposals made and information provided by our representatives shall be non-binding. Illustrations, drawings, dimensions and weights or other performance data shall only be binding if this is expressly agreed in writing.



## TERMS OF ORDER

Purchase orders shall be sent to ENEKO in written form and shall be non-binding unless they are accepted by written confirmation (order confirmation) from ENEKO. Each order shall include properly identified Products ordered and relevant shipping dates.



## PRICE OF THE GOODS

Prices are net Ex Works according to current Incoterms unless stated otherwise and do not include any kind of taxes. Prices are valid at the date of delivery will be applied. We reserve the right to adjust prices for confirmed orders as well to reflect any increase in our costs for any reason beyond our control like force majeure, shortage of primary material or labor strikes, official orders, transportation or similar problems. In this case, a new price agreement shall be required for higher rates. If such an agreement is not made, we shall be entitled to withdraw from the contract by written notice within 15 days.



## TERMS OF PAYMENT

Payments shall be carried out according to the contractual terms as defined and set forth in the order confirmation. If the payment conditions have not been agreed upon conclusion of the contract, the payment terms and payment dates specified in our invoices shall be binding. Deadlines for discounts and periods allowed for payment shall begin to run upon receipt of the invoice. Payments by draft, bills of Exchange or anyway extended payments shall mean neither credit novation, nor prejudice to the Retention of Title agreement, nor to territorial competence. If buyer fails to make payment by due date, we are entitled to charge the buyer with a relevant interest on the unpaid amount.



## TERMS OF DELIVERY

Delivery time information is only approximate. We shall only be in default if the performance is due and a written demand for payment was issued. Delivery day is the day of dispatch Ex Works. We shall also not be liable with regard to bindingly agreed periods and dates in the event of delays in delivery and of performance due to force majeure and events which considerably complicate or make delivery impossible not only temporarily-strike lockout, breakdown, delay in supply with important raw and auxiliary materials even if the delay occurs at our supplier, in particular. These delays entitle us to postpone delivery for the period of the impediment plus a reasonable start-up period or to withdraw from the contract as a whole or in part. If delivery time is extended or we are released from our delivery commitment, the buyer may not derive a claim for damages from it. However, we may only rely on the circumstances mentioned if we notify the buyer immediately. We shall be entitled to make part deliveries. Any part delivery shall be considered as independent transaction. In case of default, our liability is limited to contract-typical foreseeable damage.

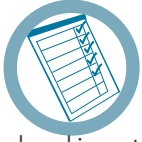

## SHIPMENT

Shipment is made for the buyer's account. Mode of shipment and shipping route, transport and packaging and other securities respectively shall be at our choice. We shall be entitled, however, not obliged to insure deliveries in the name and for account of the buyer. Risk passes to the buyer when shipment is handed over to the person performing the transport or left our Works for shipment. If shipment is delayed upon buyer's request, risk passes to the buyer with the ready for shipment note. If ordered goods are rejected after the ready for shipment note, we shall be entitled to request payment and store the goods at buyer's expense. Discharge of the goods is made at buyer's expense.



## RETENTION OF TITLE

In any event ENEKO shall retain full ownership of all materials supplied whilst the payment conditions of the entire amount have not been complied with, said materials may be removed from the customer at our request. Should the customer be declared bankrupt or insolvent and has not made paid the entire amount of payments. ENEKO shall be entitled to recover the goods. ENEKO may interrupt the supply without incurring any liability whatsoever if he had notice of or became aware of a decrease in the creditworthiness of the purchaser or if any of the existing negotiable instruments or debts were not properly complied with, shall result as being unpaid and protested.



## WARRANTY

ENEKO Products are under warranty (defect in material or workmanship) for 2 years from the date of sale reflected on the invoice. Under this warranty, ENEKO is under the obligation to replace the part requested under warranty.

The followings are excluded from ENEKO warranty:

- Normal wear and tear
- Defective assembly or handling
- Third party compensation

Parts the subject of a claim shall be sent to our warehouse as carriage paid with relevant report completely filled in, wherein the parts shall be subjected to analysis.



## LIABILITY

ENEKO, for any losses/damages, shall only be responsible within the limits of the law. Owing to basic obligations undertaken by simple negligence, if the contract is violated, ENEKO's liability shall be limited to compensate for losses which are emerged specific and predictable. ENEKO shall not carry any responsibility in case of a single negligence in breach of non-essential contractual obligations.



## PROPERTY RIGHTS

The purchaser in no event and under no circumstances whatsoever shall publish or use the trademark, trade name or logo of ENEKO without a prior written permission.



## GOVERNING LAW AND JURISDICTION

This agreement shall be governed with all aspects of the Turkish Law. The courts of Izmir/Turkey shall have an exclusive jurisdiction to adjudicate any dispute arising under or in connection with this agreement.

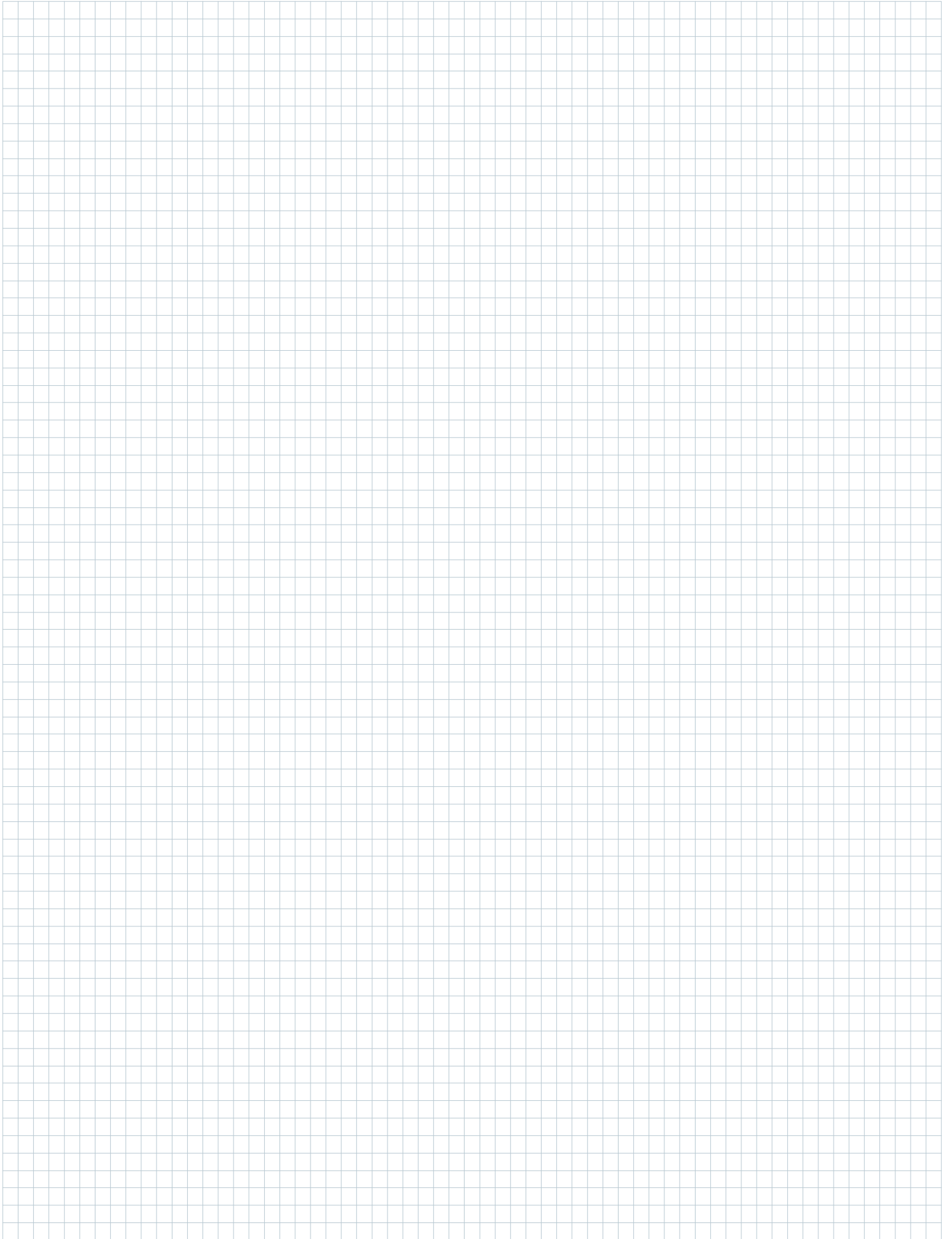

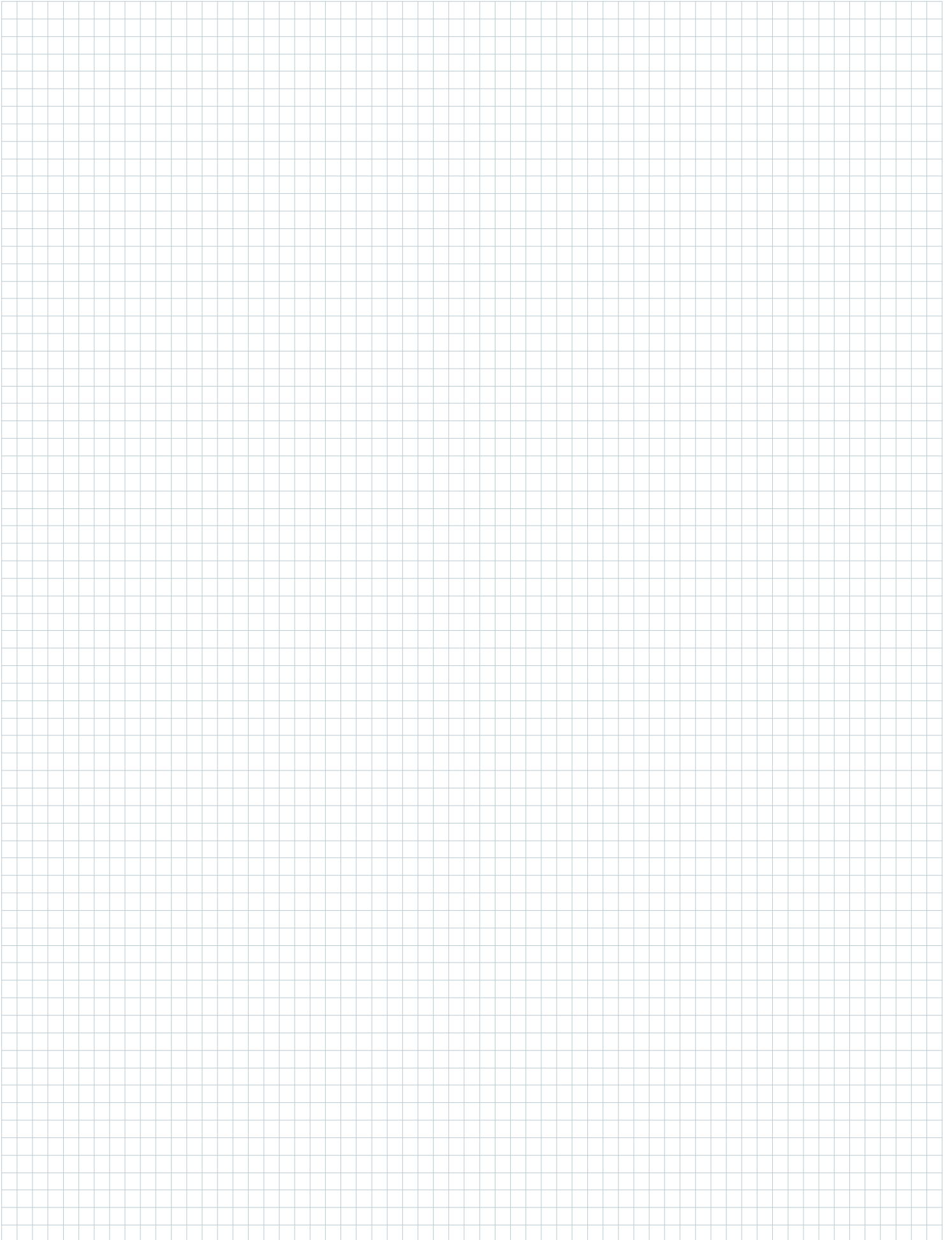



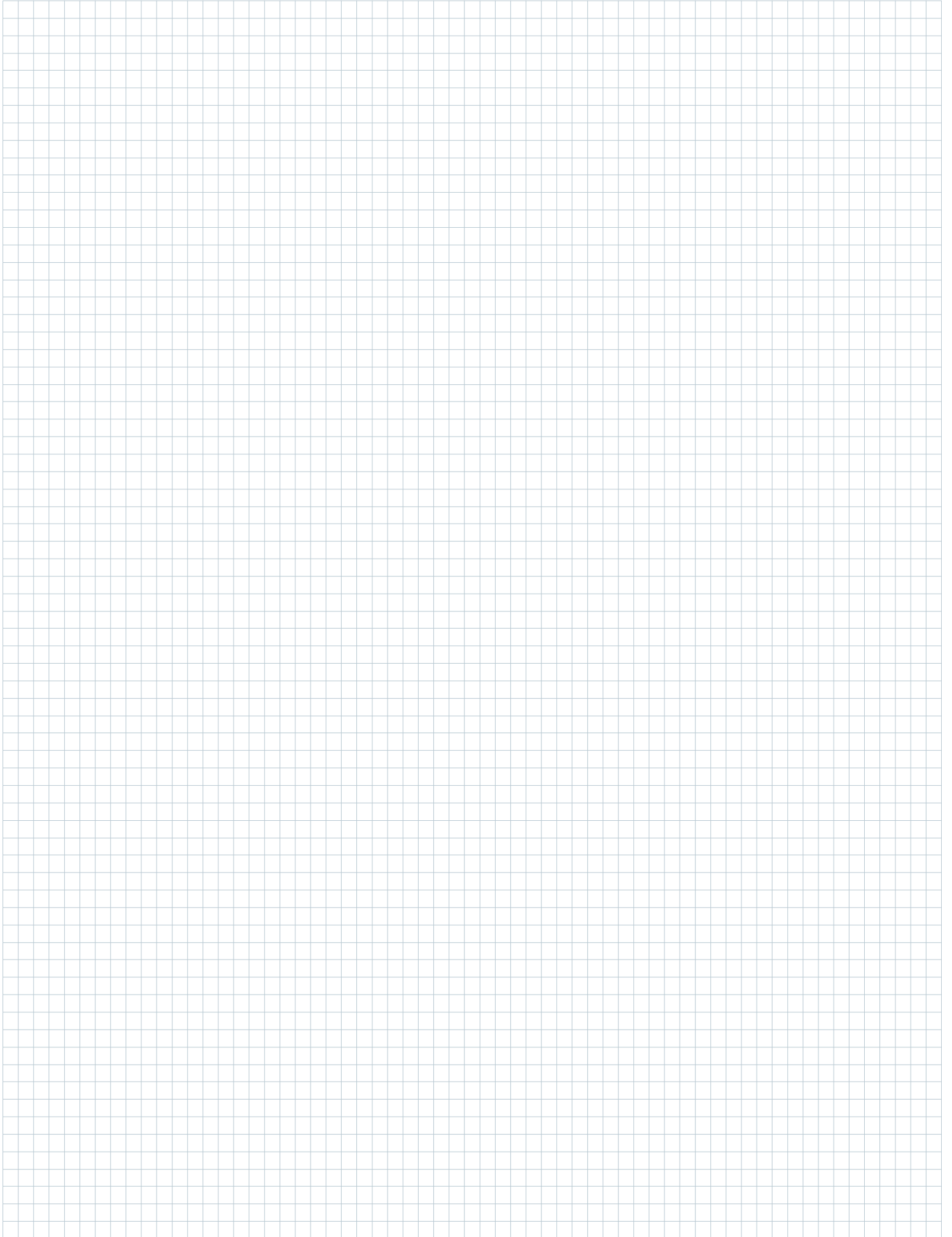

**ISTANBUL**

Address : Sahrayıcedid Mah. Halk Sok. No 27 Golden Plaza A Blok D12,  
34734 Kadıköy/İstanbul - TURKEY

Tel. : +90 216 455 29 60 / +90 216 455 29 61

Fax. : +90 216 455 29 62

**İZMİR**

Address : 10000 Sok. No:30 AOSB 35620 Çiğli/İzmir - TURKEY

Tel. : +90 232 328 20 80

Fax. : +90 232 328 20 22

Web : [www.eneko.com.tr](http://www.eneko.com.tr)

E-mail : [info@eneko.com.tr](mailto:info@eneko.com.tr)

In parallel with our ongoing product development in R&D department, all rights of changing all technical specifications are reserved by ENEKO without any declaration and notice.

